

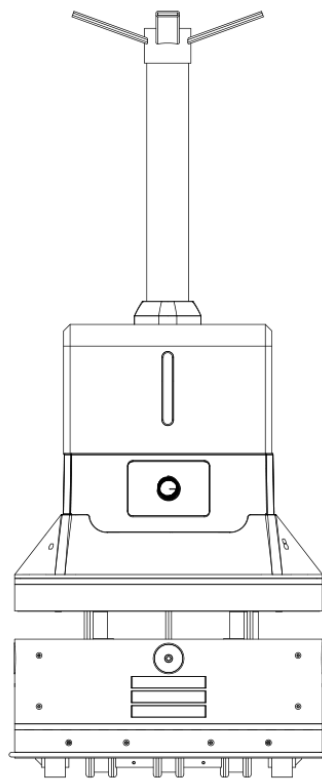



# **BKS-ST-180C**

## **Product Manual**

V2.0.4



BOOCAX

 0086 4001618661

## Safety and Precautions

The use of spray robot shall follow the operation instructions. Use beyond the range is prohibited! BooCax will not assume any responsibilities for the losses caused by improper operation.

Symbols:

- ⊗ indicates prohibited acts.
- ⚠ indicates danger, warning and attention.

### ⊗ PROHIBITIONS

- KEEP OUT DURING SPRAYING;
- DO NOT USE IN FLAMMABLE GAS ENVIRONMENT;
- DO NOT ADD ANY ADDITIVE OF UNKNOWN SOURCE INTO THE WATER TANK;
- DO NOT CLEAN OR ADD WATER WHEN THE ROBOT IS POWERED ON;
- DO NOT DISASSEMBLE THE ROBOT FOR REPAIR OR DEBUGGING;
- DO NOT TOUCH THE TERMINALS WHEN THE ROBOT IS UNDER CHARGE TO AVOID SHORT CIRCUIT OR ELECTRIC SHOCK;
- DO NOT REPLACE ANY PARTS. IF NECESSARY, PLEASE DO SO UNDER THE DIRECTION OF BOOCAX.

### ⚠ PRECAUTIONS

- THE SPRAY ROBOT SHOULD BE PARKED IN A FLAT AND SOLID PLACE AT NORMAL TEMPERATURE;
- WHEN ADDING LIQUID, DO NOT SPLASH LIQUID INTO THE ROBOT;
- IF THERE IS ODOR OR ABNORMAL NOISE DURING SPRAYING, PLEASE IMMEDIATELY TURN OFF THE ROBOT AND REPORT TO THE AFTER SERVICE;
- BEFORE STARTING THE ROBOT, PLEASE CHECK WHETHER THE SAFETY COMPONENTS (SENSOR, EMERGENCY STOP SWITCH, ETC.) ARE IN NORMAL CONDITIONS;
- IF THE FLOOR IS WATERLOGGED AND GREASY, PLEASE CLEAN THE FLOOR PROMPTLY;
- BEFORE REMOVING ANY PARTS, PLEASE CONFIRM THAT THE POWER IS OFF;
- THE ROBOT BODY MUST BE MAINTAINED BY A TRAINED PROFESSIONAL.

## Table of Contents

<b>1. Introduction to Spray Robot</b> .....	<b>3</b>
1.1. Product Features .....	3
1.2. Suggestion for use .....	4
1.3. Product specification .....	5
1.4. Appearance size .....	6
1.5. Function module .....	7
<b>2. Assembly</b> .....	<b>9</b>
<b>3. Install the charging pile</b> .....	<b>12</b>
<b>4. Clean up barriers</b> .....	<b>13</b>
<b>5. QR code deployment</b> .....	<b>13</b>
<b>6. Download mobile App</b> .....	<b>15</b>
<b>7. Turn on, connect the robot</b> .....	<b>15</b>
<b>8. Build the spraying map</b> .....	<b>17</b>
<b>9. Set the function points</b> .....	<b>18</b>
<b>10. Set up scheduled tasks</b> .....	<b>21</b>
<b>11. Add liquid</b> .....	<b>21</b>
<b>12. Start spraying</b> .....	<b>22</b>
<b>Attachment: update instructions</b> .....	<b>23</b>

## 1. Introduction to Spray Robot

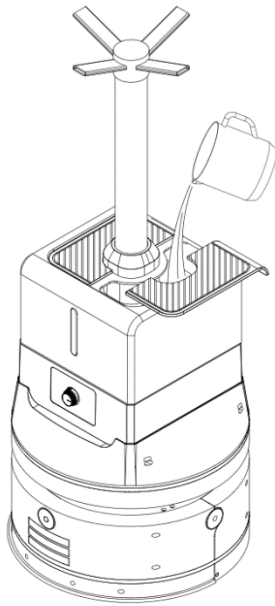

BooCax BKS-ST-180C atomizing spray robot is designed to purify the air by rapidly atomizing the liquid and automatically spraying the area.

This robot can automatically navigate to the area for full-coverage spraying, and supports mobile App control to achieve man-machine separation and minimize personnel exposure, so that the use safety is greatly improved. With simple structure, it is easy to maintain and manage.

The spray robot is widely applicable to hospitals, airports, office buildings, shopping malls, schools, factories and other public places.

### 1.1. Product Features

- ① The spray volume is up to 2600 ml/h, with the atomized particles less than 10 microns;
- ② The spray diameter is 5 ~ 6 m, leaving no dead corners in the spraying area;
- ③ 16 L large-capacity tank covers a spraying area up to 20000 m<sup>2</sup>;
- ④ It is simple to use with mobile App control and supports two spraying modes: regular spraying, immediate spraying;
- ⑤ It can automatically detect the obstacles without manual monitoring, thus reducing the burden on personnel;
- ⑥ The autonomous navigation function enables a full coverage of the spraying area;
- ⑦ With 4.5 hours of battery life, repeated charging is not needed;
- ⑧ Automatic return for charging spares the trouble of artificial assistance for charging;
- ⑨ When the liquid is lower than the warning level, the robot will automatically close the spray device and returns to the waiting area.

## 1.2. Suggestion for use

User type		Spraying scenarios	Suggestion for use
<b>Medical institution</b>	<ul style="list-style-type: none"> <li>• Hospital</li> <li>• Clinic</li> </ul>	Registration hall, waiting hall, internal working area, canteen, fever clinics, warehouse, etc.	✓ Medical institution level.
<b>Station</b>	<ul style="list-style-type: none"> <li>• Railway station</li> <li>• Bus station</li> <li>• Subway</li> <li>• Airport</li> </ul>	Five accesses and one platform (station entrance, ticket gate, elevator entrance, station exit, platform), waiting room (airport lounge)	✓ Real-time spraying at "five accesses and one platform": medical institution level; ✓ Regular spraying in waiting room: public health security level.
<b>School</b>	<ul style="list-style-type: none"> <li>• Kindergarten</li> <li>• Primary and secondary school</li> <li>• University</li> </ul>	Lecture hall, library, indoor sports hall, classroom, laboratory, toilet, cafeteria, office area, etc.	✓ Daily scheduled spraying: public health security level.
<b>Office area</b>	<ul style="list-style-type: none"> <li>• Office building</li> <li>• Office block</li> <li>• Administration service hall</li> <li>• Bank outlet</li> </ul>	Toilets, halls, corridors, elevator rooms, offices, etc.	✓ Real-time spraying at entrance/exit: medical institution level; ✓ Daily scheduled spraying: public health security level.
<b>Shopping mall</b>	<ul style="list-style-type: none"> <li>• Shopping mall</li> <li>• Supermarket</li> </ul>	Entrance/exit, counter, rest area, service desk, cashier desk, elevator, and other public areas	✓ Real-time spraying at access and in other crowded areas: medical institution level; ✓ Scheduled spraying in other areas: public health security level.

<b>Hotel</b>	• Guesthouse	Hotel lobby, toilet, floor corridor, guest room, restaurant, etc.	✓ Spraying in guest room and restaurant: medical institution level.
	• Hotel		✓ Spraying in other areas: public health security level.

### 1.3. Product specification

<b>Name</b>	<b>Spray Robot</b>
<b>Model</b>	<b>BKS-ST-180C</b>
<b>Application</b>	<b>Indoor automatic atomizing spray</b>
Appearance size	Diameter 530 mm* Height 1,340 mm
Body weight	48.4 kg (without liquid)
Spray rate	Maximum 2600 ml/h (adjustable)
Tank volume	16L
Spray diameter	≤ 6 m
Spray mode	Four-direction nozzle or One-direction nozzle
Movement mode	Autonomous path planning and auto-navigation
Moving speed	0.3 m/s
Obstacle surmounting ability	≤15 mm
Gradeability	≤8°
Travel lane width	≥750 mm
Noise	≤50dB
Continuous running hours	4.5hours
Charging mode	Auto-charge
Charging time	3 hours (0-80%)
Charging pile	INPUT:110V-220V AC OUTPUT:DC29.4V=8.0A
Safety protection	low water alarm

### 1.4. Appearance size

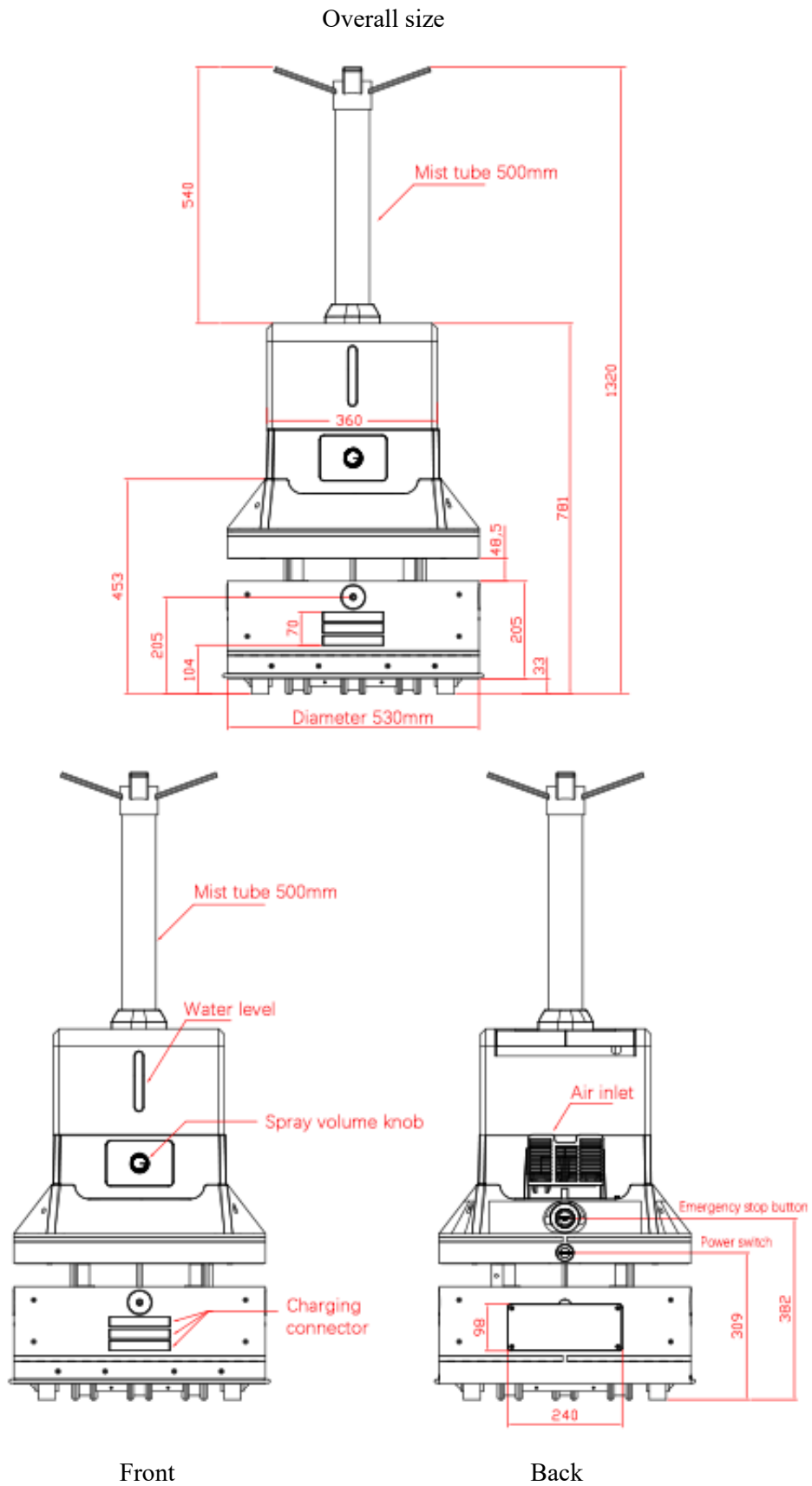

### 1.5. Function module

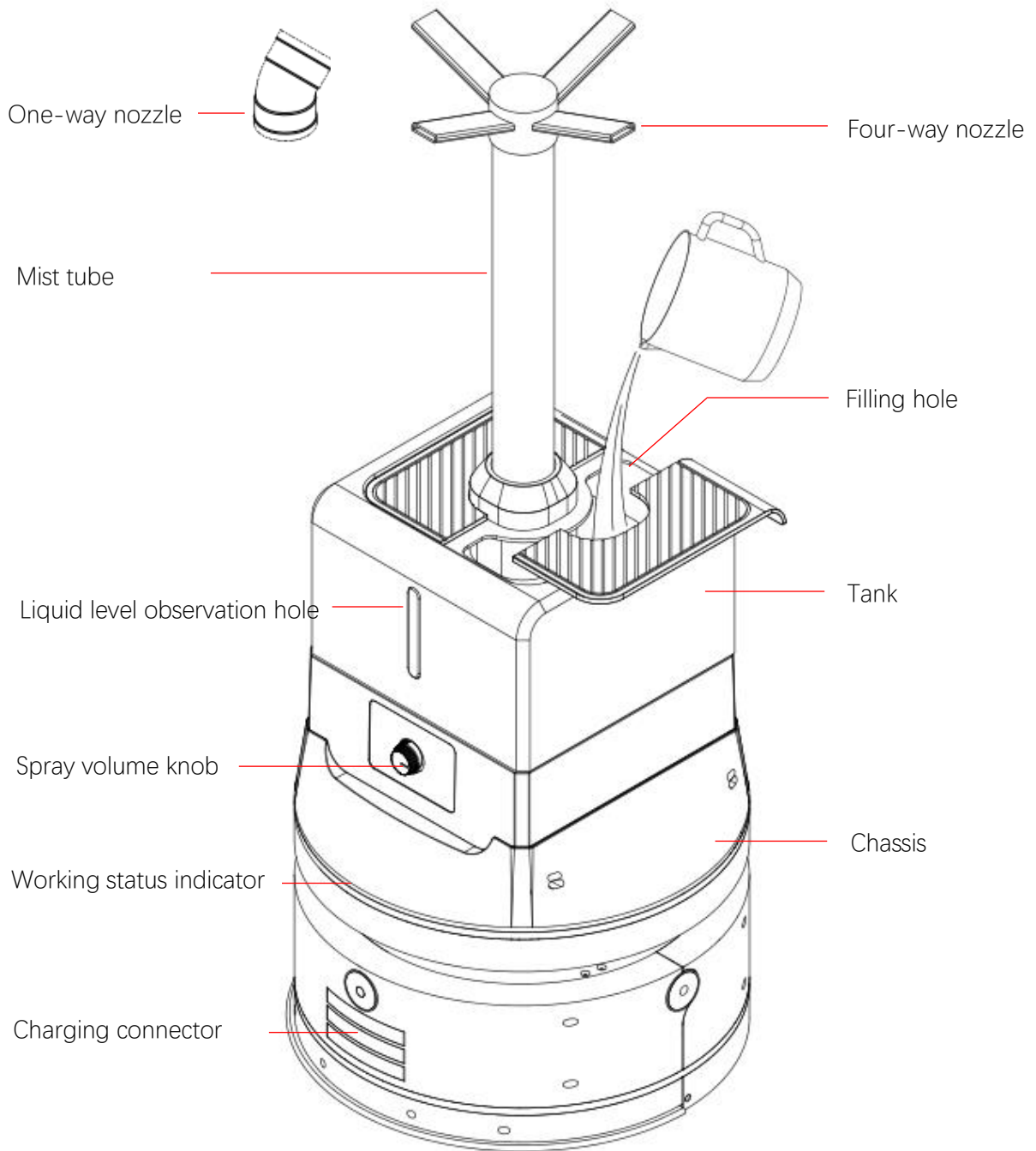

Front



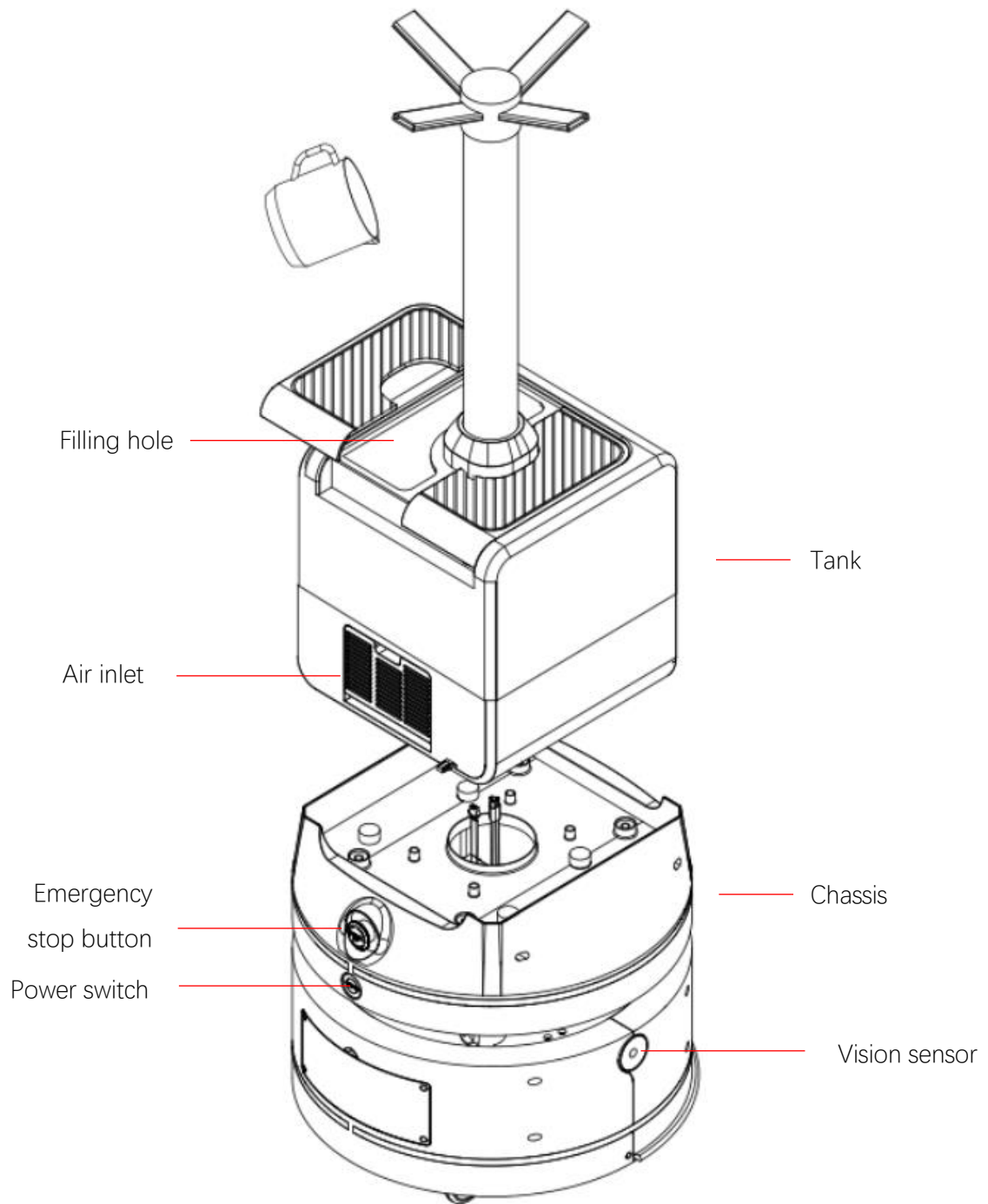

Back

## 2. Assembly

### Step 1: Unpack and check materials

The packaging of this product consists of two boxes, with the larger box for the chassis and charging pile, and the smaller box for the robot body. After unpacking, check the materials and accessories against the Nos.1-8 in the figure below for any missing or damage.

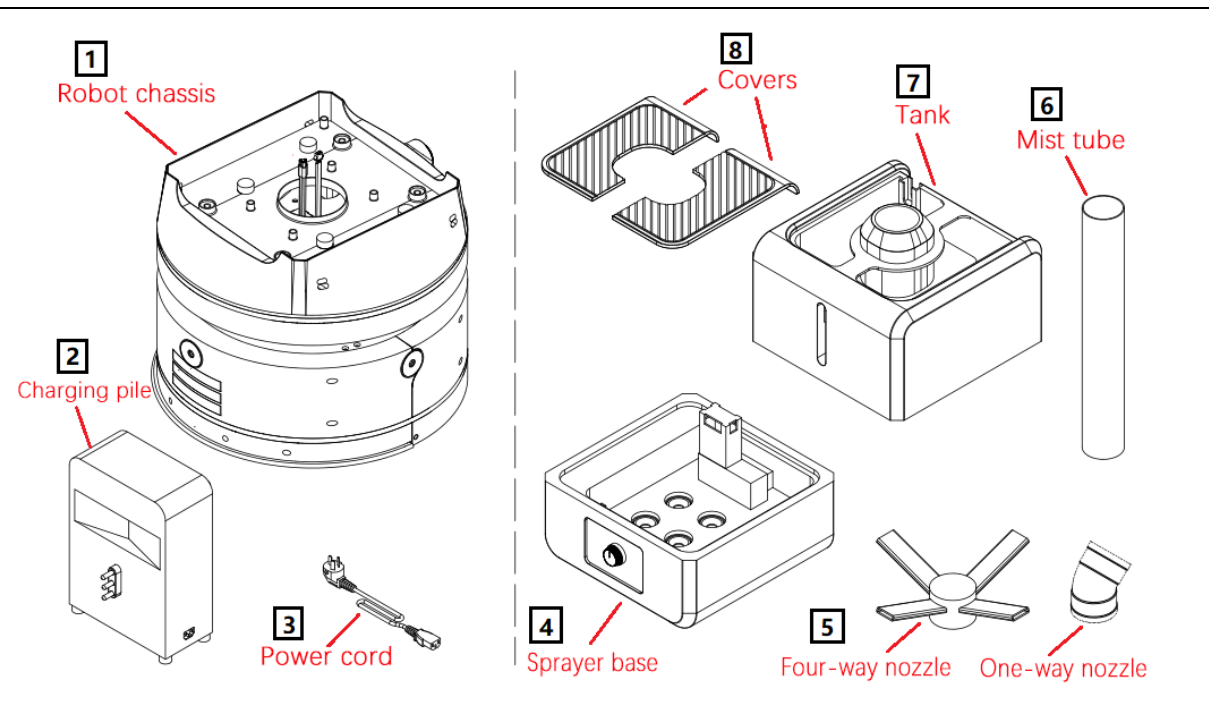

### Step 2: Install the sprayer

- ① Take out the chassis and place it on the floor stably, make sure that the lower charging mouth is facing forward, pull out the two connectors (Terminal 1: signal wire, Terminal 2: power wire), and visually find the four positioning holes on the iron plate →

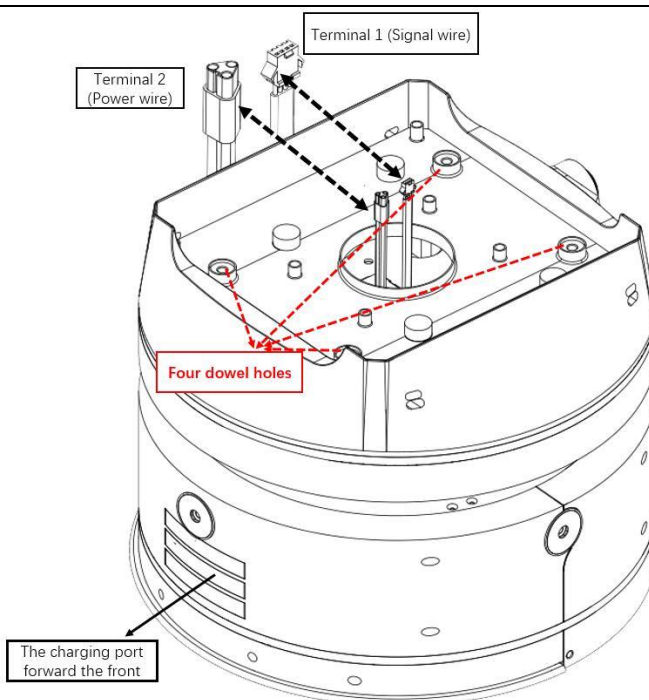

② Turn the direction of knob on the sprayer base forward, and then pull out the two connectors (Terminal 1, Terminal 2 as shown) at the bottom to match the male and female connectors on the chassis. Four dowels are aligned with the four positioning holes on the chassis (note that the lower charging mouth of the chassis is also facing forward) so that it falls smoothly and snaps into place →

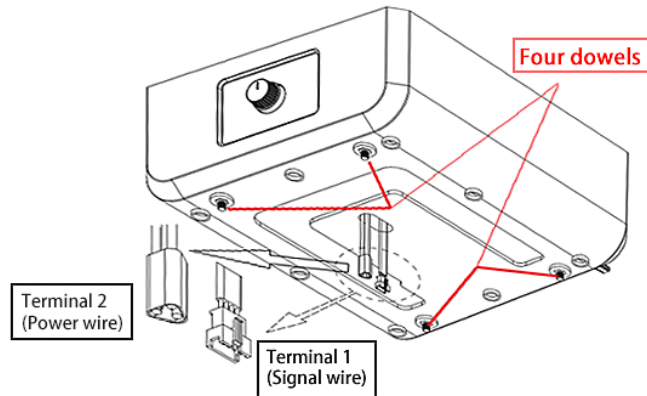

③ Remove the protective foam from the water control valve on the sprayer base to ensure that the next stack of water tank is not hindered →

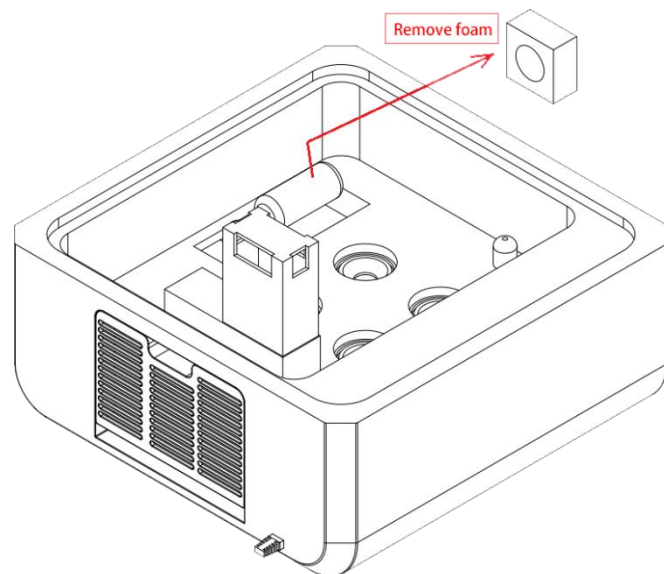

**Step 3:** Dock the water tank and robot base cable

Lift the water tank stably, stack it on top of the sprayer base.

Relying on the positioning steps that sink around, it can be freely in place from top to bottom under the action of gravity →

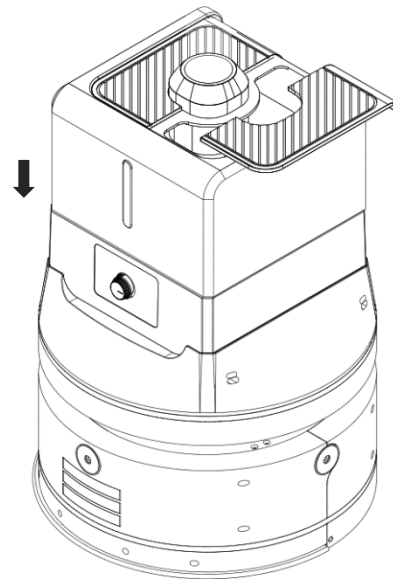
**Step 4:** Install mist tube and four-way nozzle

Finally, remove the mist tube, insert one end into the circular outlet at the center of the water tank, and then put the other end on the top into a four-way nozzle for connection (for tight connection, it is recommended to wrap it with waterproof tape before putting it in) →

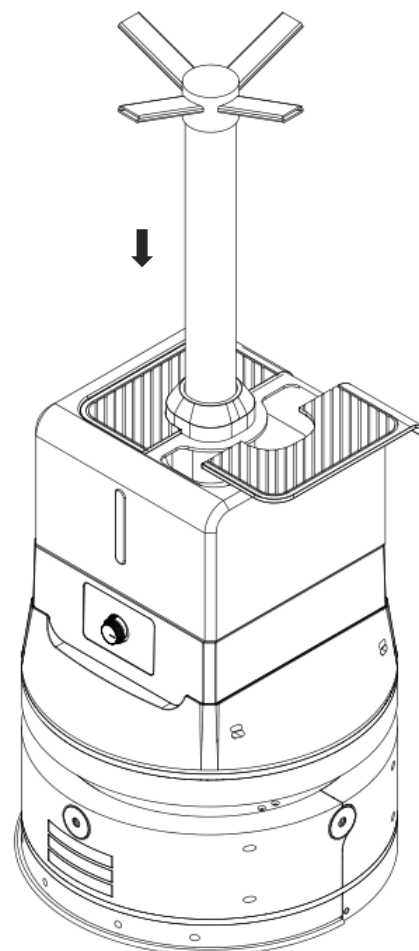

### 3. Install the charging pile

The charging pile of the spray robot should be placed in a safe and tidy place. It should be on the horizontal ground with its back against the flat wall (it is better to fix the charging pile to the ground or wall). As shown in the following figure:

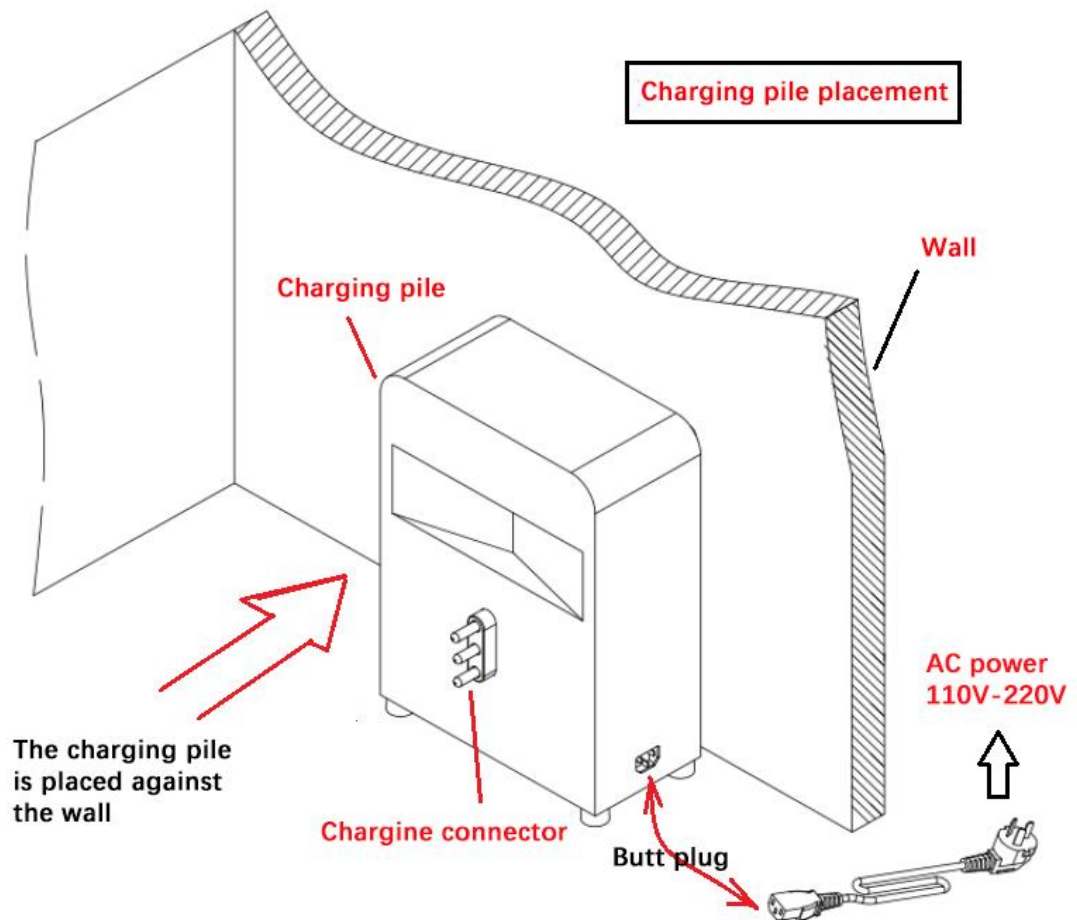

Schematic Diagram of Installation and Use of Charging Pile

- ① Place the back of the charging pile against the wall, and then turn the foot pads at the bottom to adjust the charging pile.
- ② Plug the 3-pin female socket end of the three-plug power cord into the 3-pin male end of the adapter, and connect the other end to a 110V/220V AC socket to officially complete the power-on preparations.

## 4. Clean up barriers

- 1) Before using the spray robot, remove the barriers in the aisle to avoid affecting the working and charging of the robot;

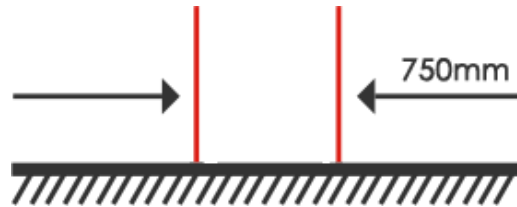

The minimum walking width of the robot is 750mm

- 2) Make sure that there is no vertical step over 15mm in the spraying area, and no objects (books, boards, stones, etc.) over 15m m in height on the working path;



The surmounting height of the robot is 15mm

- 3) Make sure that there is no large slope on site:



The maximum gradeability of the robot is  $8^\circ$ .

## 5. QR code deployment

In order to enhance the positioning accuracy of the robot, we designed a QR code scheme to ensure that the robot's long-term running position is not lost. The QR code is generally used where the robot positioning is prone to deviation, for example, the two ends of a long corridor, in which case, a QR code can be pasted at a distance of 10m from the two ends to assist positioning.

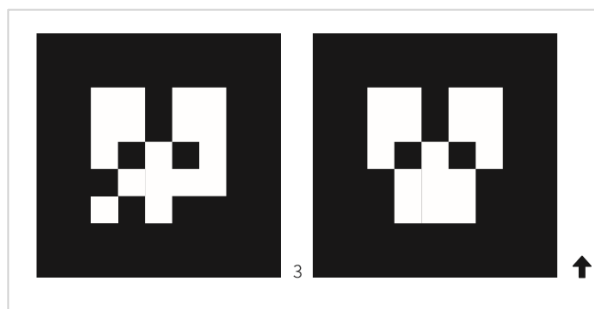

### 1) Precautions for QR code pasting

- Avoid deploying at a place with strong light, so as not to affect the camera to capture the QR code image;
- The QR code should be pasted at the same level as the camera;
- Paste the QR code in the direction as the arrow;
- If the QR code is damaged, replace it in time.

### 2) The example is shown below



### 3) Precautions for saving QR code

- No duplicate QR code boards can appear in the same environment;
- When mapping, the robot stops at the QR code board for 1-2 seconds to ensure that the QR code is saved (Voice prompt will be given for successful identification);
- The QR code of the charging pile should be identified by the camera in front of the robot, and the QR code of a corridor can be identified by the cameras on the left and right;
- When incrementally mapping, it is necessary to ensure that the robot's positioning is accurate before identifying and saving the QR code.

## 6. Download mobile App

Android 8.0 and above mobile phone Scan the QR code below download the corresponding App

and install it 



Android mobile browser scan to download the App

## 7. Turn on, connect the robot

- 1) Turn on the switch to initiate the working mode of the robot

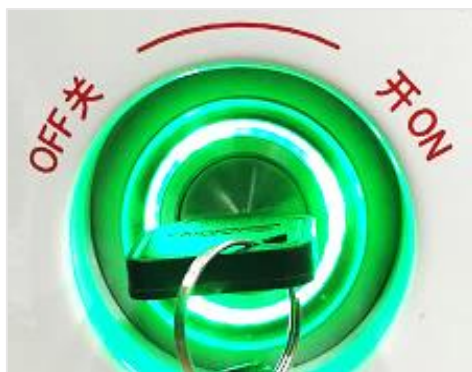

Power switch

- 2) Turn on the phone wifi, search the wifi network beginning with "BKS-ST-180C", and enter the assigned password "robot123" to connect the robot

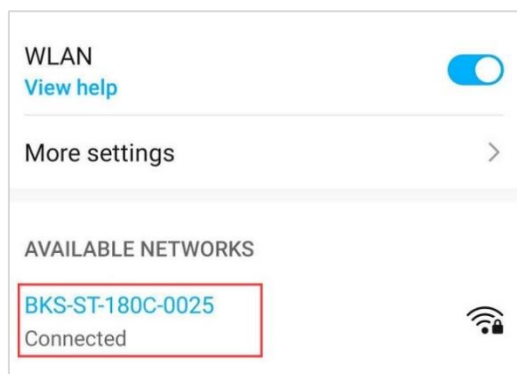



- Open the App, you will find the robot beginning with "BKS-ST-180C-0025" (as shown in the following figure), click login

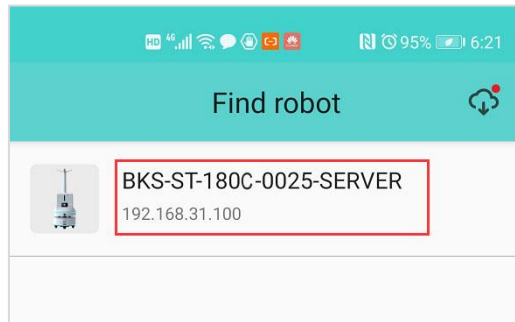

“BKS-ST-180C-0025” is the dedicated network for spray robot.

- Open the App to show the interface shown in the following figure.

Homepage of Robot Control App:

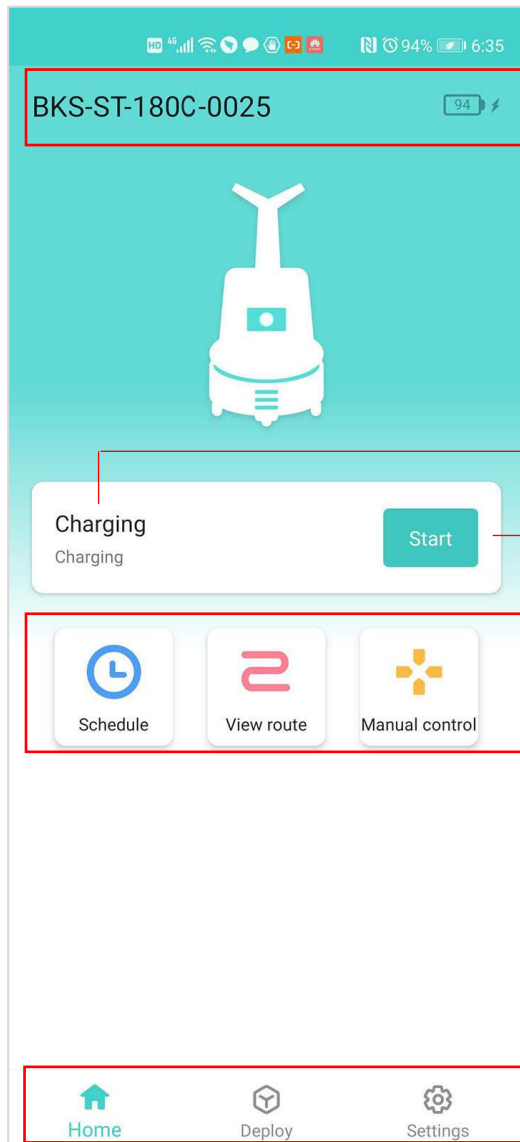

- Robot name
- Battery

- Robot status
- Start

Three main function menu buttons:

- Schedule (Working time setting button)
- View route (View robot working route)
- Manual control (Manual control switch button)

Main control menu:

- Home
- Deploy
- Settings

## 8. Build the spraying map

Click "deploy" on the homepage of App to show the "**Build Map**" button. Click the button to build a two-dimensional spraying map, as shown in the following figure (**Push the robot by hand to build the map**):

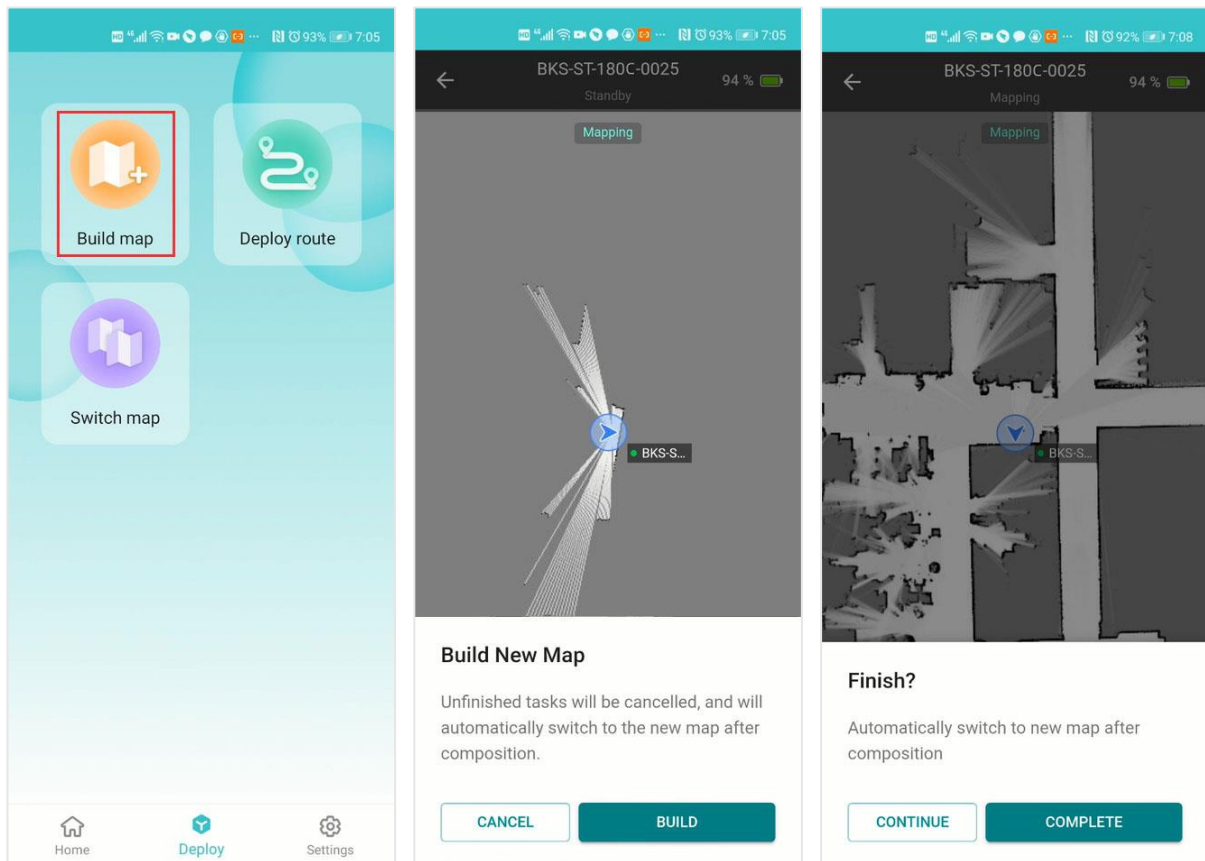

Legends:

- White radius—the range scanned by the laser;
- Black thick line—the scanned obstacles (special objects such as transparent glass may not be identified);
- Red thick line—the obstacles scanned by laser in real time;
- Gray area: Area that has not been scanned.

After the map is built, the robot can locate and navigate on the new map.

### ⚠ Attention:

- ① When mapping by hand, push the robot forward slowly in the scene from the charging pile as the starting point, and finally return to the charging pile to form a large circle;
- ② When mapping, don't be too close to the wall and keep a distance of at least **0.5m**;

- ③ The operator must stand behind the robot to avoid leaving noise on the map;
- ④ When turning, walk slowly so that the robot can collect as much characteristic point data as possible;
- ⑤ As laser radar does not recognize accurately in abnormal environment (glass, mirror, pure black object, grid, etc.), it is recommended to carry out appropriate treatment, such as pasting frosted sticker, gray adhesive tape, etc.;
- ⑥ If the working scene is too large and there are too many noises in the first mapping, you can use "incremental mapping" for local repair.

## 9. Set the function points

Before starting use, the necessary spray start point, spray end point and route shall be set in advance. The working path of the robot consists of the starting point, several path points (**deploy while walking**), and the end point.

**The user can choose to deploy the route by:**

- 1) Pushing the robot deployment point;
- 2) Set on the App interface, move the map to set the point.

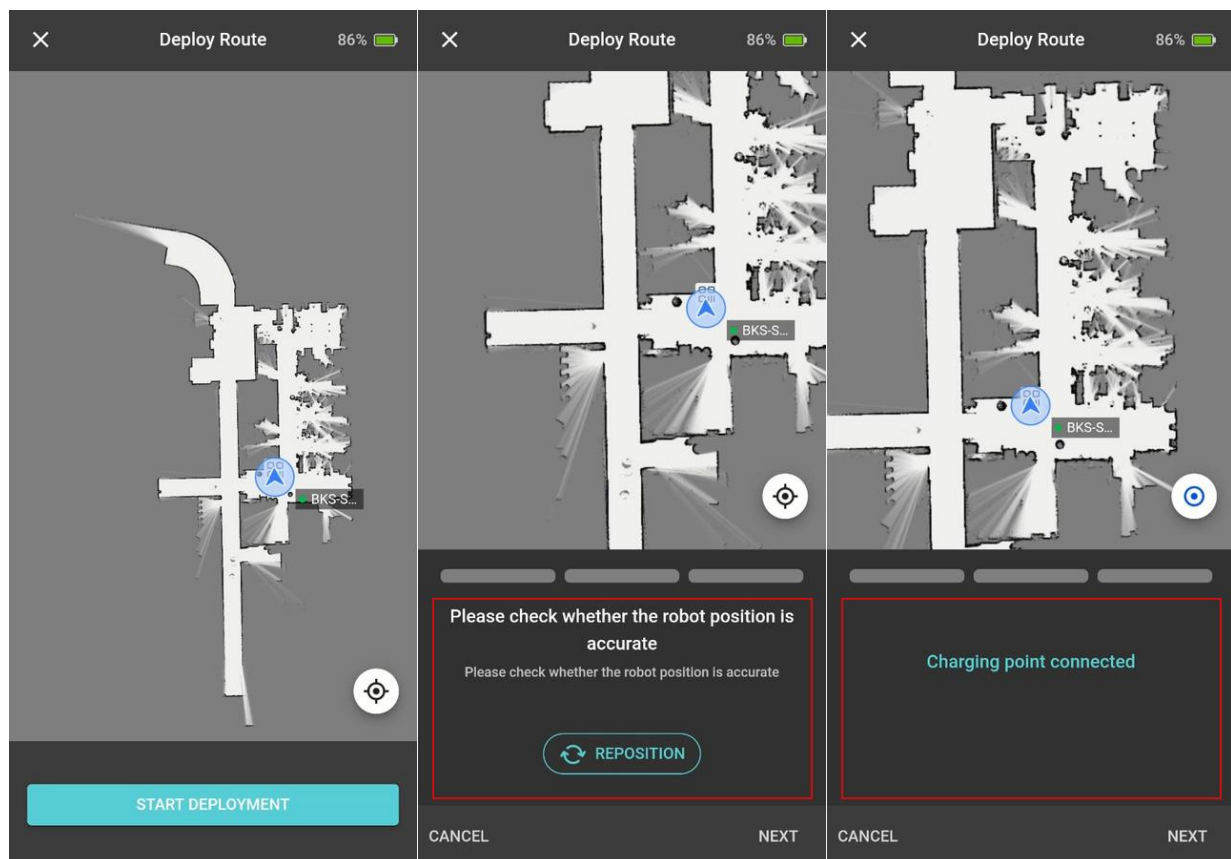

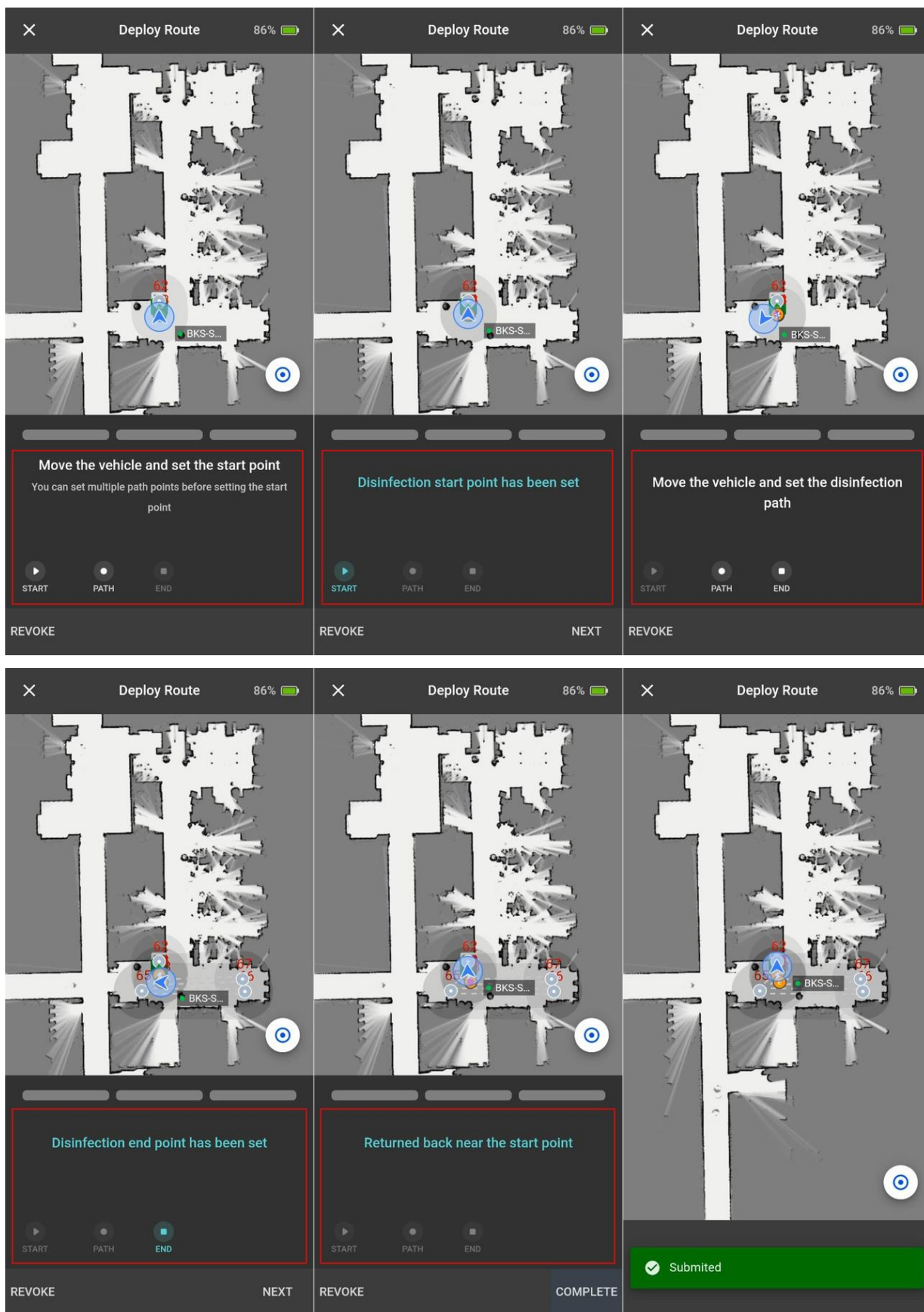

**⚠ Attention:**

When mapping, the turning should be deployed with waypoints which cannot pass through the wall, as shown in the figure below:

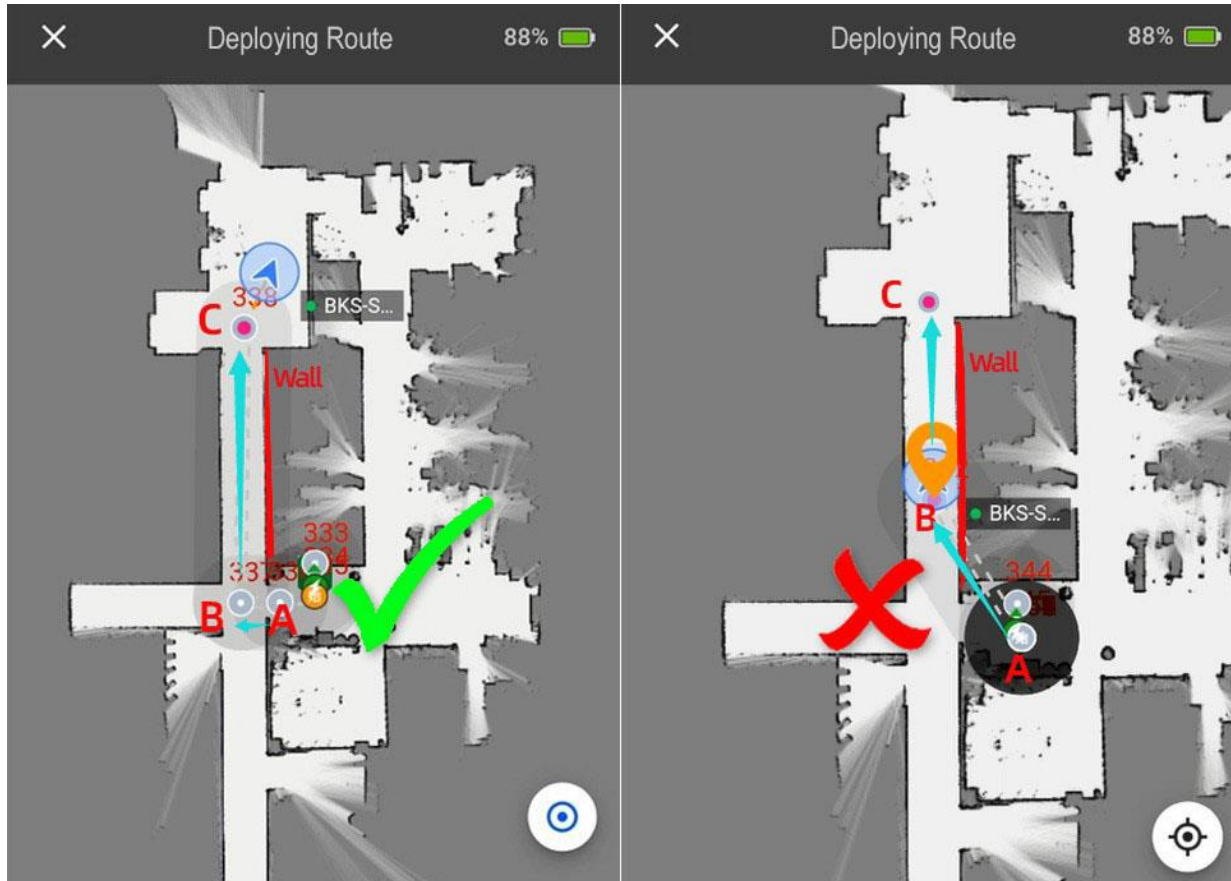

As shown in the figure above, when the robot has to move from A to C, but is obstructed by a wall or an unmovable obstacle in between, the correct path deployment should be A-B-C. B must be set as it is the key node of the turning. The figure on the right shows the wrong deployment, in which the path will go through the wall directly, causing the robot unable to walk.

## 10. Set up scheduled tasks

Set the start time and spraying frequency as needed (as shown in the following figure). These two settings can be adjusted at any time.

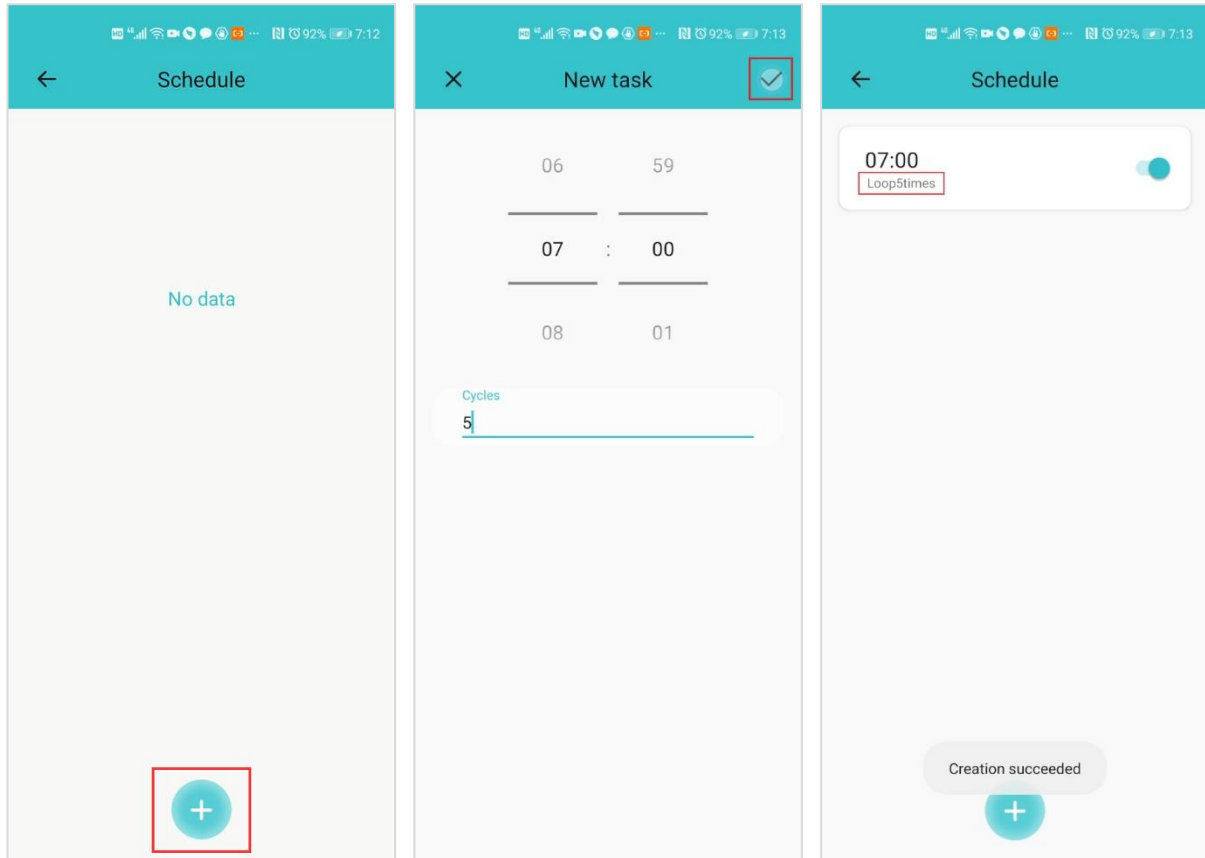

## 11. Add liquid

The working principle of BKS-ST-180C atomizing spray robot is purifying the air by rapidly atomizing the liquid and automatically spraying the area.

Support the use of conventional disinfectants such as hypochlorous acid and chlorine dioxide or fast water-soluble disinfection tablets. All disinfectants should be used immediately before use to avoid impairing the disinfection effect due to oxidation and volatilization.

### **⚠ Attention:**

It is recommended that the maximum volume of liquid should not exceed **12L**, in order to avoid overflow in up and down ramps, access trenches, thresholds, emergency stops and other working conditions.

As shown in the figure:  
Remove the cover of the  
tank to add water and  
other liquids.

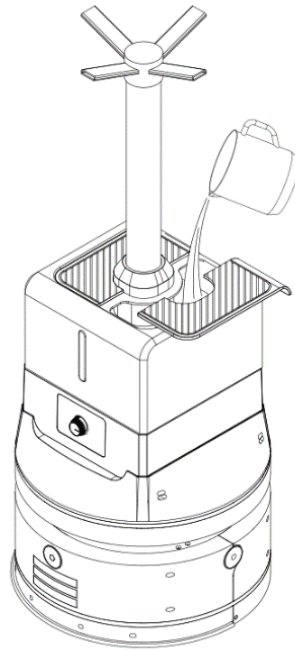

## 12. Start spraying

When all preparations are ready, return to the homepage of App, click the "start" button, and the robot will start spraying according to the settings.

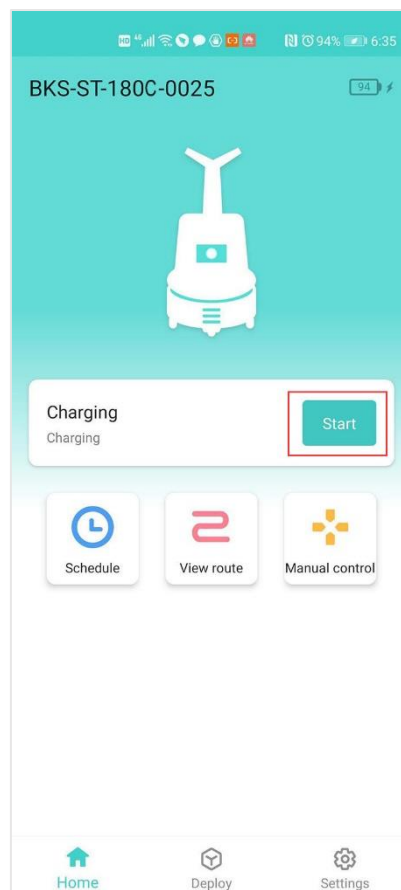

## Attachment: update instructions

### Step1: Verify model

Two ways can be confirmed:

- 1) Check with the product manual (you will get the corresponding model manual when you buy the robot);
- 2) Check the code on the back of the robot, for example **BKS-ST-180C-0025** it corresponds to the "ST-180C" model;

### Step 2: Download the firmware

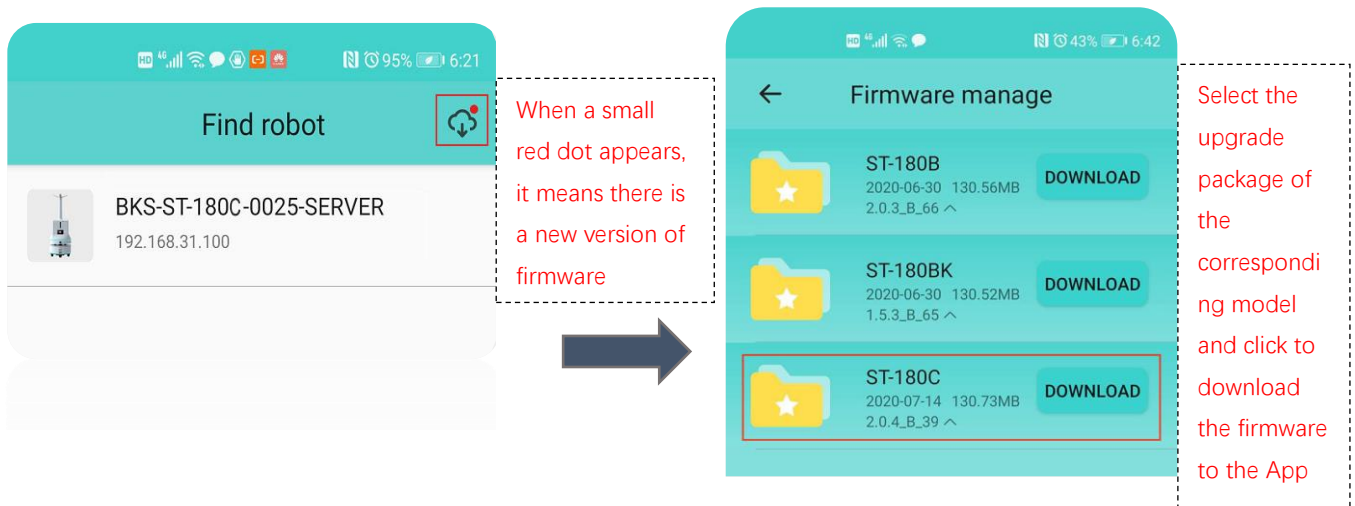

### Step 3: Connect the robot

Turn on the mobile phone wifi, find the robot, enter the password to connect (Please refer to section 7 of section 2 of the manual) :

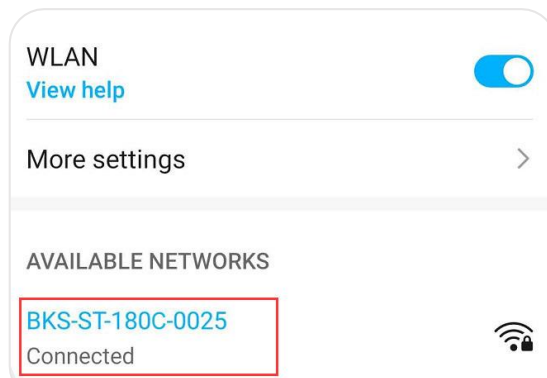



**Step 4: App upgrade firmware to robot**

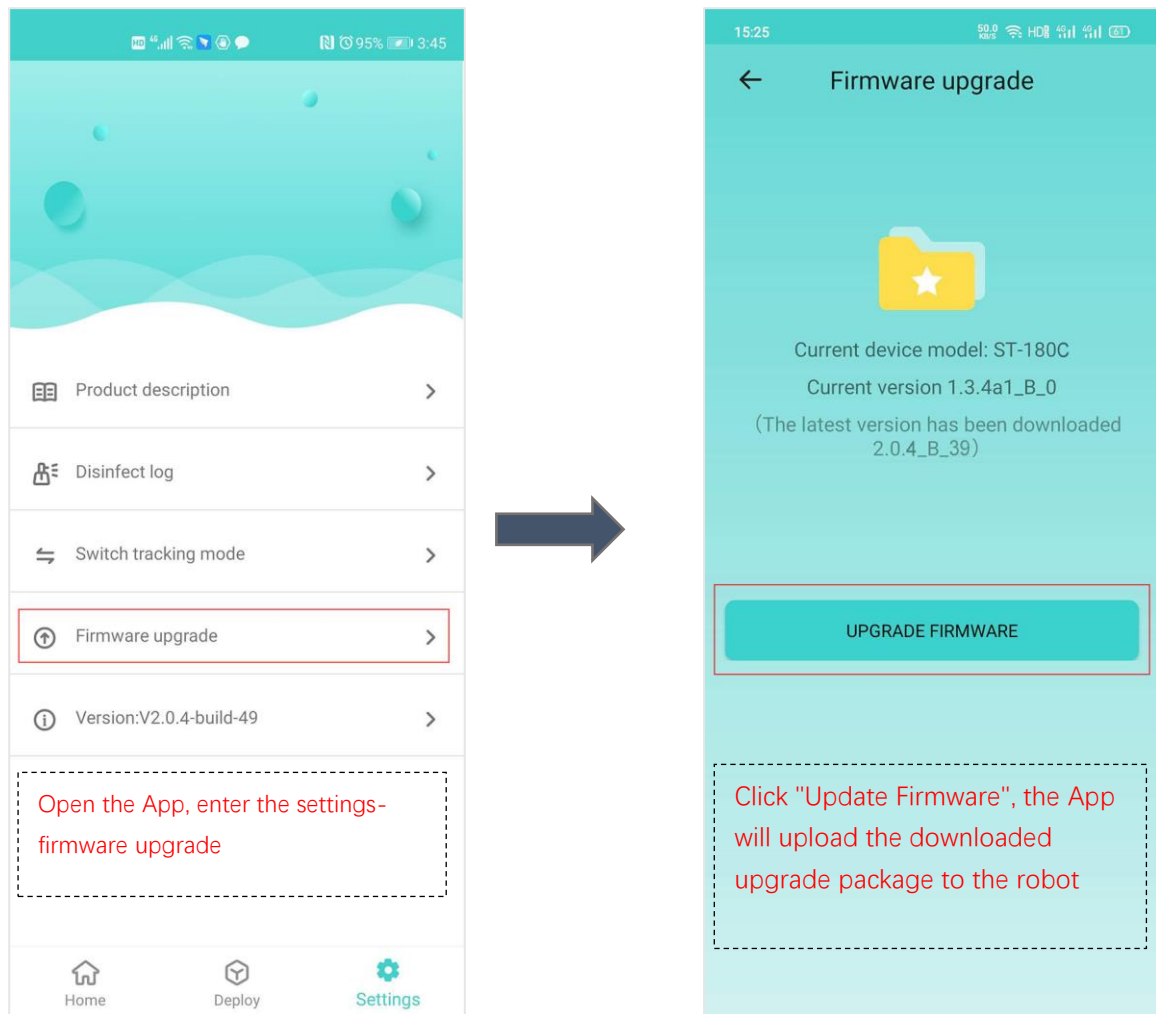

**⚠ Special attention:**

- ② When upgrading, please do not power off or turn off the power;
- ① The whole process of firmware upgrade is about **5 minutes**. During this period, any operation on the robot is prohibited.



[www.boocax.com](http://www.boocax.com)

Business cooperation / after-sales: 0086-400-161-8661

Beijing Headquarter:	Shenzhen Branch:	Shandong Branch:
Room 606, Jianjin Center, Yongtaiyuan A No.1, Qinghe, Haidian District, Beijing	3F, Building 10, COFCO Fu'an Robotics Industrial Park, Fuyong Street, Baoan District, Shenzhen	No.269 Hengfeng Road, Zoucheng Central Electromechanical Industrial Park, Ji'ning, Shandong