

BooCax Terminal Disinfection Robot

BKS-ST-180A

Product Manual

V 1.0.0

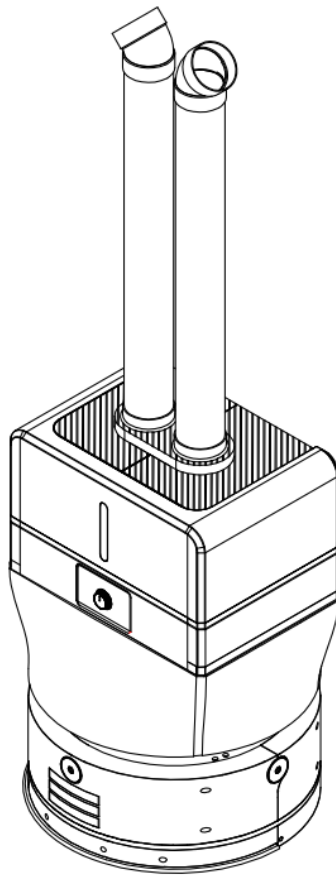

BOOCAX ROBOTICS



400 -161- 8661

Safety and Use Precautions

Please follow the operation instructions of the product when using the robot. It is forbidden to use beyond the scope! The company will not assume any responsibility for the loss caused by improper operation beyond the standard.

01/ Instructions on safety matters in use of robots

1) Behaviors below are prohibited,

- ① Stay in the space where the robot is disinfecting;
- ② Robots are used in flammable gases and similar hazardous environments;
- ③ Add any disinfectant not suitable for this product to the tank;
- ④ Cleaning, wiping and other non-necessary operations when the robot is on;
- ⑤ Unauthorized disassembly of the robot for repair or debugging;
- ⑥ Touch the circuit terminal while the robot is charging;
- ⑦ Replace any parts without authorization (If necessary, please do so under the company's approval and guidance);
- ⑧ To transport the robot while its tank is still with hydrogen peroxide disinfectant

2) Safety instructions for use

- ① The robot should be parked and run as far as possible in a flat, solid, normal temperature condition;
- ② When adding hydrogen peroxide, do not splash to other parts of the robot;
- ③ If abnormal sound is found during the disinfection work, please immediately turn off the power of the robot and report to the after-sales service for treatment;
- ④ Before starting the robot, please check whether the safety device (sensor, emergency stop switch, etc.) is normal;
- ⑤ If discover the road with water and greasy, please clean the road, to remove greasy;
- ⑥ When to maintain the robot, it must be carried out by trained professionals;
- ⑦ If the robot is not to use for a long time, it must keep the tank out of any liquid and promote it to a cool and dry place for preservation.

02/ Safety instructions for using hydrogen peroxide

Please strictly comply with all requirements of hydrogen peroxide.

03/ Daily maintenance instructions

When cleaning the tank, please use the matching cleaning detergent, make sure the robot is power off and unplugged or away from the charging pile! Otherwise, electric shock or serious failure may occur.

It is strictly prohibited to flush the robot and charging pile directly with tap water, which may lead to the accumulation of water vapor or water inside the equipment and cause serious irreparable failure.

1) Cleaning

- ① Please refer to the use method and attention of detergent for cleaning the tank;
- ② Regularly brush the surface of the driving wheel and universal wheel;
- ③ Use neutral detergent and dust-free cloth to gently wipe the outer surface of the robot regularly
- ④ Regularly contact after-sales for maintenance services such as lubrication, dust-cleaning at the damping spring and universal wheel bearing;
- ⑤ Lidar sensor, as the expensive precision component in robot, should be wiped regularly with a non-dust cloth. Do not wipe with force or other detergent, which may be easy to cause functional damage.
- ⑥ If the robot will not be used for a long time, store it in a dry and cool place.。

2) Check whether the screw is loose

Shake the components gently on a regular basis to observe whether they are loose. If there is any abnormal sound, please check the screws at the installation position of relevant components. All the screws of the robot have undergone anti-loosening treatment. However, for the sake of safety, please contact "BooCax After-sales" if any screw is found loose。

04/Disclaimer

BooCax company owns multiple patents related to this robot product. No organization or individual may use these patents without authorization.

The robot has precise internal structure. For the sake of safety, no one is allowed to disassemble the robot without permission except the authorized personnel of BooCax, otherwise the warranty will be invalid. BooCax will not assume any responsibility for any damage, breakdown and property/personal injury caused by unauthorized disassembly. The identification of unauthorized disassembly will be subject to the anti-disassembly mark on the robot body.

05/ After-sales

If you have any questions about maintenance, safety and other issues during use of BooCax robot, please contact us by phone or email provided on the back of this manual. We are very willing to provide you with product-related services.

06/About "Terminal Disinfection"

Refer to Article "**11.2.1.5**" in the "**Health Industry Standards of the People's Republic of China**" -**WS/T 367-2012** Technical Specifications for Disinfection in Medical Institutions, Terminal disinfection is performed after surgery, patient discharge, transfer, or death. The terminal disinfection can be fumigated with 3% hydrogen peroxide or peracetic acid, to aerosol spray by 3% hydrogen peroxide per 20mL/m³, to heat and fumigate by Peracetic acid at 1g/m³, humidity 70%-90%, make it airtight for 24H. Or to aerosol spray by 5% peracetic acid per 2.5mL/m³, humidity 20%-40%.

目录

| | |
|---|-----------|
| 1. Introduction to Terminal Disinfection Robot | 4 |
| 1.1. Product Features..... | 4 |
| 1.2. Product Specification..... | 5 |
| 1.3. Appearance Size..... | 6 |
| 1.4. Function Modules..... | 7 |
| 2. Assembly | 8 |
| 3. Install the charging pile | 11 |
| 4. QR code deployment | 12 |
| 5. Clean up barriers | 13 |
| 6. Download mobile App | 14 |
| 7. Turn on, connect the robot | 14 |
| 8. Build map..... | 16 |
| 9. Deploy Route/Area setting | 17 |
| 9.1 Deploy route setting..... | 17 |
| 10 Schedule setting..... | 21 |
| 11. Other settings..... | 21 |
| 12. Start to work | 22 |
| 12.1 Add liquid..... | 22 |
| 12.2 Start spraying | 22 |
| Attachment: Upgrade | 23 |

1. Introduction to Terminal Disinfection Robot

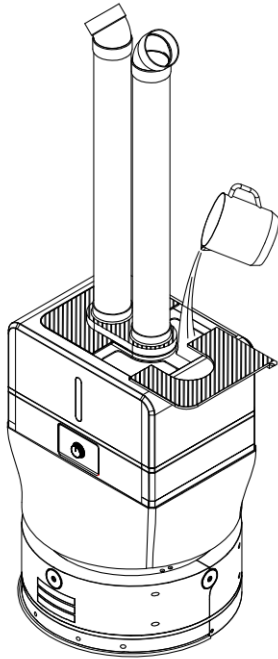

BooCax BKS-ST-180A terminal disinfection robot is designed to purify the air by rapidly atomizing the Hydrogen peroxide or similar terminal disinfectant and automatically spraying the indoor area.

This robot can automatically navigate to the area for full-coverage spraying, and supports mobile App control to achieve man-machine separation and minimize personnel exposure, so that the use safety is greatly improved. With simple structure, it is easy to maintain and manage

This robot is applicable to the indoor area where need Hydrogen peroxide or similar terminal disinfectant for terminal disinfection.

1.1. Product Features

- ① Atomizing the disinfectant into dry mist, the atomized particle is as small as **5 μ m** in diameter.
- ② Atomizing rate reaches 3200ml/hour,
- ③ The spray diameter is 5 ~ 6 m(maximum), leaving no dead corners in the spraying area,
- ④ 16 L ultra large-capacity tank,
- ⑤ By mobile App control and supports two spraying modes: regular spraying, immediate spraying, and record the disinfection log automatically,
- ⑥ With functions of autonomous navigation, disinfection route(area) setting and schedule setting,
- ⑦ Applicable to multi-area (room), layout complex environment, ensure the uniformity and consistency of disinfection,
- ⑧ Automatic obstacle-detect function with APP and voice prompt function,
- ⑨ Support auto-charging, free users from the cable trouble,
- ⑩ When the liquid is lower than the warning level, the robot will automatically close the spray device and returns to the charging pile.

1.2. Product Specification

| Item | Name | BooCax Terminal Disinfection Robot |
|--------------------|-----------------------------------|---|
| | | Model No. |
| Basic data | Application | Auto terminal disinfection by hydrogen peroxide and similar disinfectant solution |
| | External Size | Diameter 600mm, Height 1660mm (with 500mm spray tube) |
| | Net weight | 52.5kg (exclude disinfectant) |
| Spray Function | Spray rate | Maximum 3200 ml/h |
| | Tank Volume | 18L maximum |
| | Spray diameter | ≤ 6 m |
| | disinfectant | Hydrogen peroxide and similar disinfectants for terminal atomization disinfection |
| | Spray mode | Multiple directions (single-nozzle/dual-nozzle for choice) |
| Motion Performance | Movement mode | Can plan route and set area, with auto-navigation |
| | Moving speed | 0.3 m/s |
| | Driving | Differential drive |
| | Obstacle surmounting | ≤10 mm |
| | Gradeability | ≤8° |
| | Gradeability Travel lane width | ≥ 750 mm |
| Endurance | Endurance | ≥ 3 小时 (by max spray rate continuously) |
| | Battery | 28Ah (The full battery voltage is 29.4V) |
| | Charging Way | Auto-charging、10-90% by 3 hours |
| | Charging pile | Support 110V ~ 240V wide voltage input Rated output: voltage 29.4V, current 8.0A |
| Safety | Safety protection | low water alarm |
| | Emergency stop | yes |
| | Bumper Strip | yes |
| | Noise | ≤60dB |
| | Working temperature | 10°C ~ 40°C |

1.3. Appearance Size

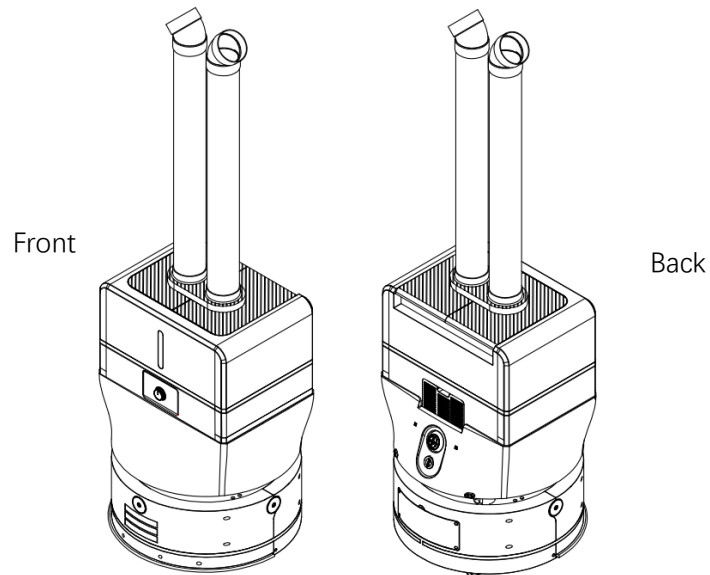
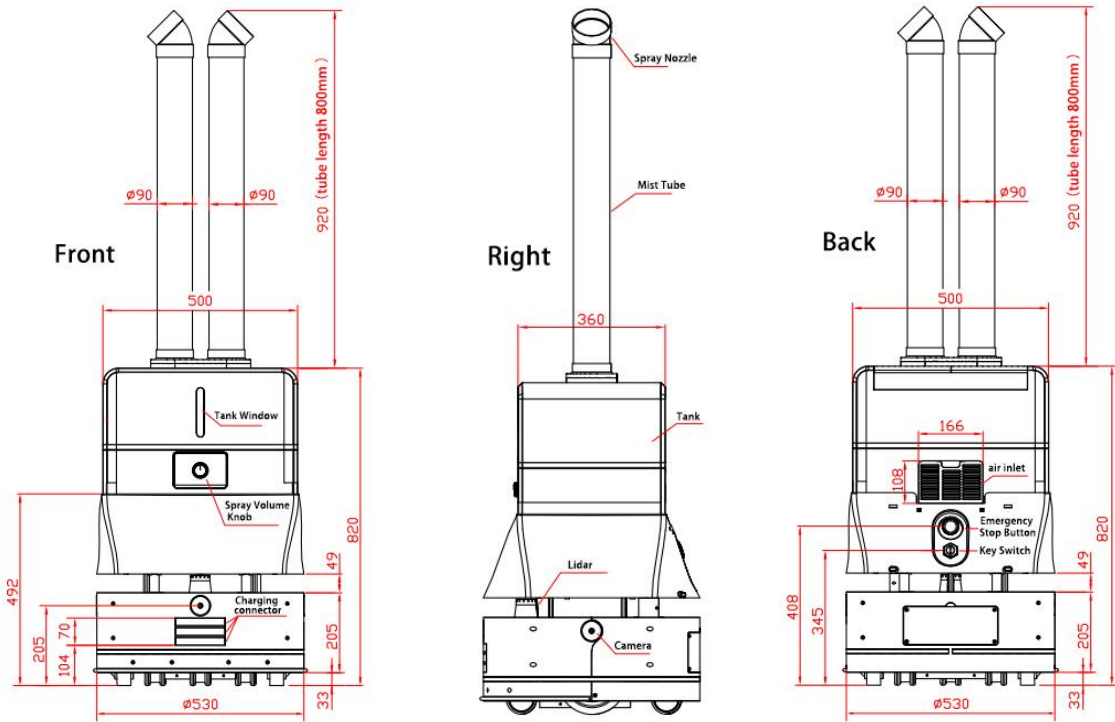

1.4. Function Modules

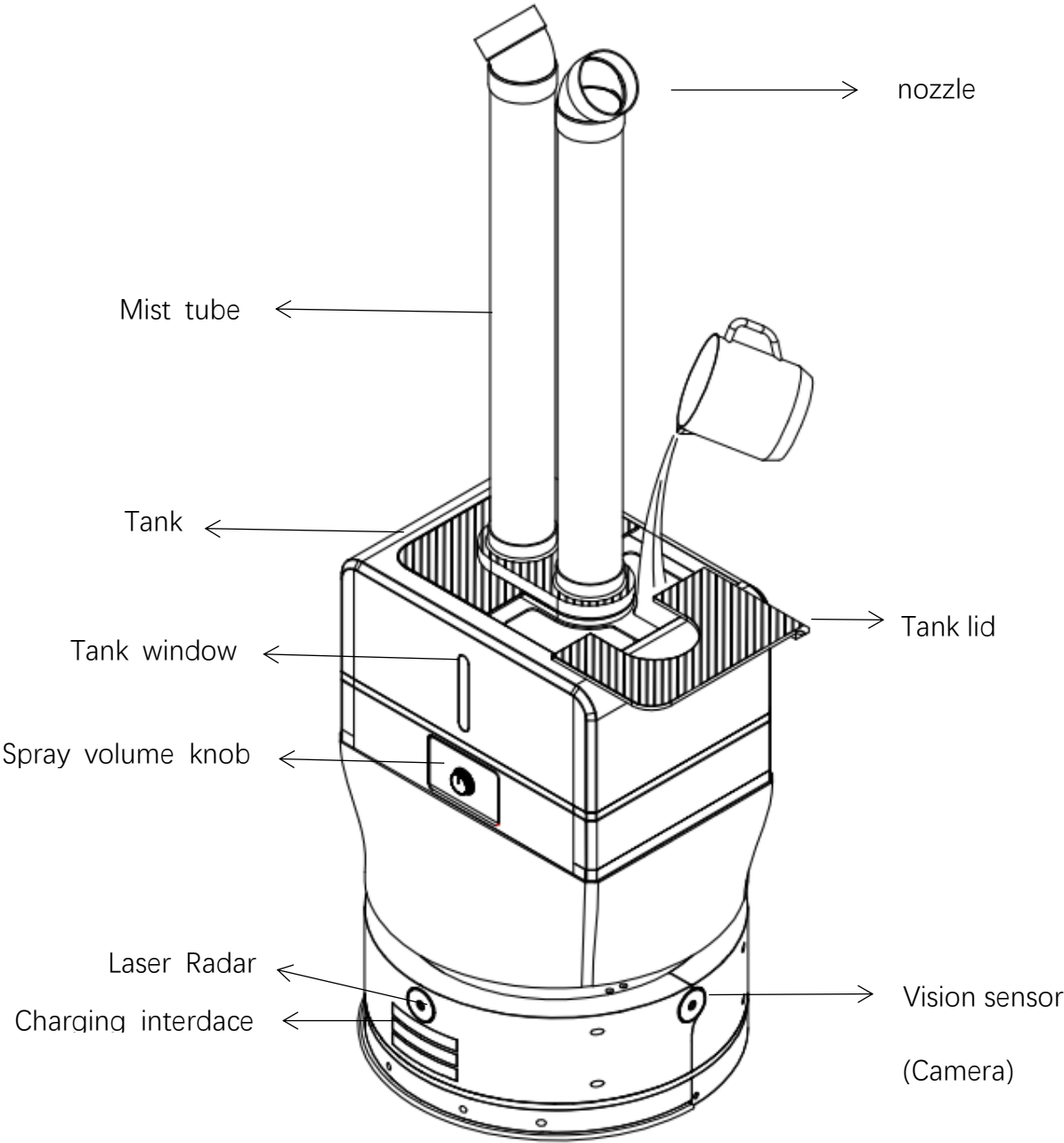

2. Assembly

Step 1: Unpack and check materials

The packaging of this product consists of two boxes, with the larger box for the chassis and charging pile (①-③), and the smaller box for the robot body(④-⑧). After unpacking, check the materials and accessories against the Nos.1-8 in the figure below for any missing or damage (**Package concludes two one-way nozzles, and two mist tubes**).

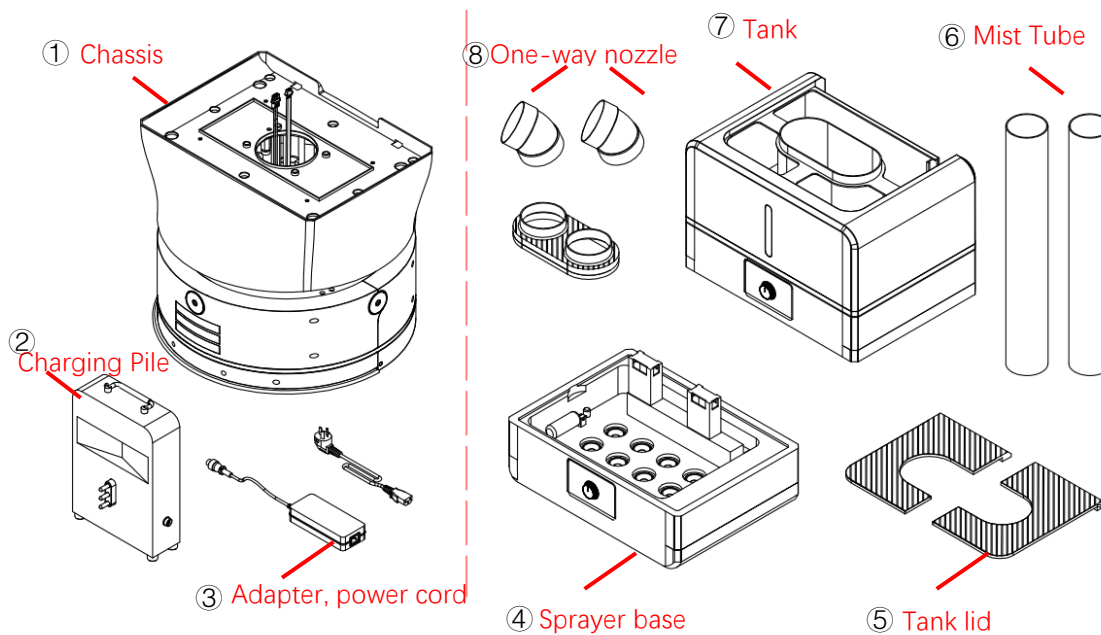

Step 2: Install the Sprayer

① Take out the chassis and place it on the floor stably, make sure that the lower charging mouth is facing forward, pull out the two connectors (Terminal 1: signal wire, Terminal 2: power wire), and visually find the four positioning holes on the iron plate →

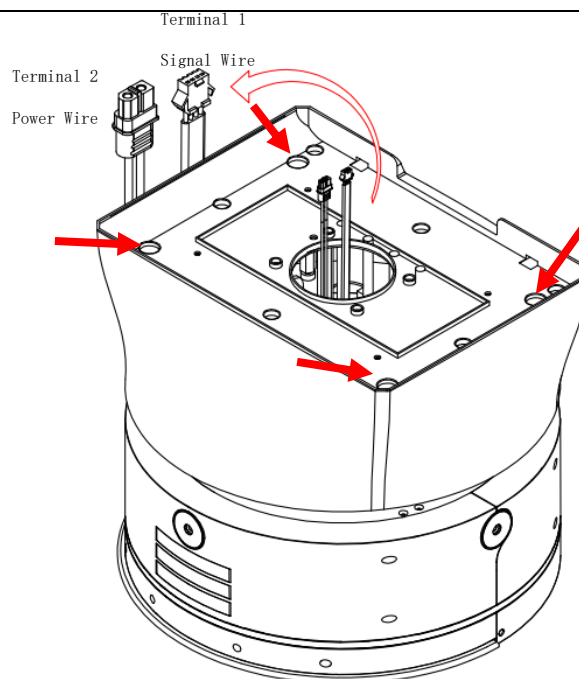

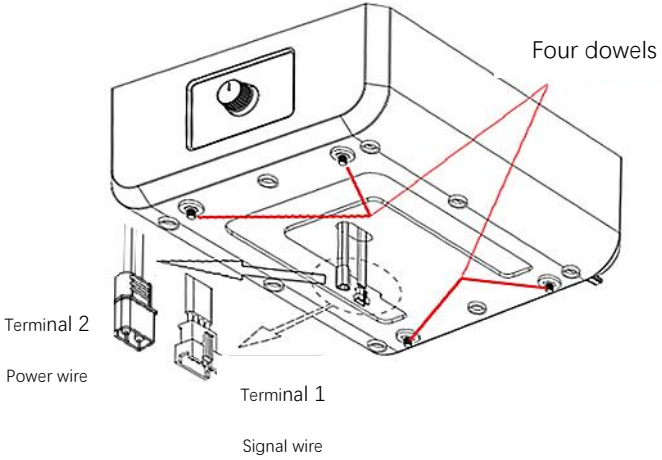
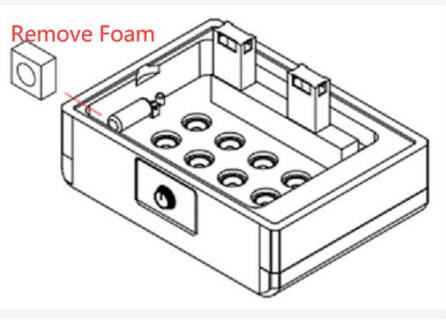
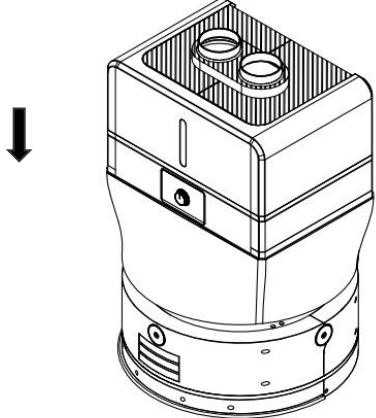
| | |
|--|--|
| <p>② Turn the direction of knob on the sprayer base forward, and then pull out the two connectors (Terminal 1, Terminal 2 as shown) at the bottom to match the male and female connectors on the chassis. Four dowels are aligned with the four positioning holes on the chassis (attention that the lower charging mouth of the chassis is also facing forward). Make it fall smoothly, buckle in place →</p> |  |
| <p>③ Remove the protective foam from the water control valve on the sprayer base to ensure that the next step of placing tank is not hindered</p> |  |
| <p>Step 3: Dock the tank and robot Chassis</p> | |
| <p>Lift the water tank stably, stack it on top of the sprayer base. Relying on the positioning steps that sink around, it can be freely in place from top to bottom under the action of gravity →</p> |  |

Step 4: Install mist tube and nozzle

Take out the mist tube, insert one end into the circular outlet at the center of the water tank, and then connect the other end on the top with nozzles (for tight connection, it is recommended to wrap it with waterproof tape before putting it in, single-tube mode or dual-tube mode is optional to switch) →

Note: To reach the maximum spray rate, you may select the single-tube mode with one-way nozzle.

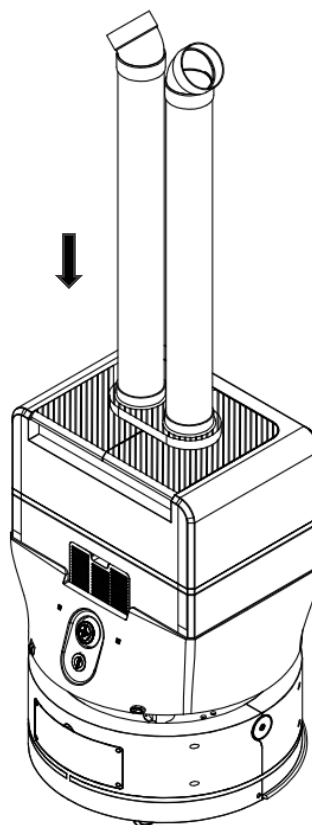

3. Install the charging pile

The charging pile of the spray robot should be placed in a safe and tidy place. It should be on the flat ground with its back against the flat wall. As shown in the below figure:

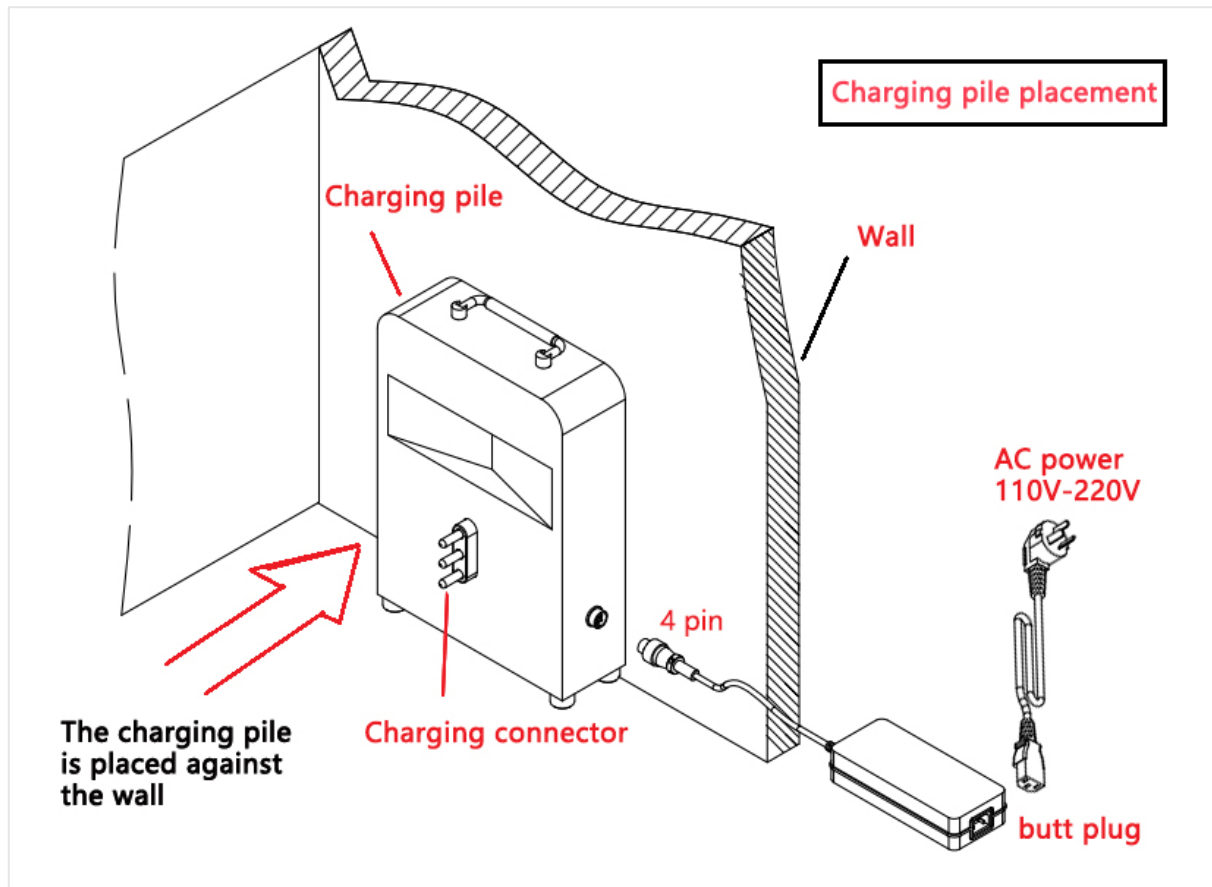

- ① Place the back of the charging pile against the wall, and then turn the foot pads at the bottom to adjust the charging pile.
- ② Connect the power cord, adapter, and charging pile as shown above, and finally connect the end of the power cord to the 110V / 220V AC socket to formally complete the boot preparation.

4. QR code deployment

In order to enhance the positioning accuracy of the robot, we designed a QR code scheme to ensure that the robot's long-term running position is not lost.

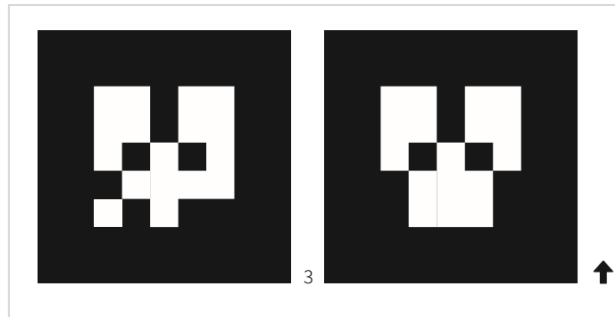

The QR code is generally used where the robot positioning is prone to deviation, for example, the two ends of a long corridor, for example, the two ends of a long corridor, in which case, a QR code can be pasted at a distance of 15m from the two ends to assist positioning.

Also, In relatively empty scenes, QR Code is also need to assist positioning.

1) Standard of QR code pasting

- Avoid deploying at a place with strong light, incase the strong light will affect the camera to capture the QR code image;
- The QR code should be pasted at the same level as the camera;
- Paste the QR code per the direction of the arrow pointed (marked in below picture)
- Replace the QR Code once it is damaged.

Referenced to below:



2) Precautions for QR code

- a) Two same QR codes are not accepted in same environment,
- b) When mapping, the robot stops at the QR code board for 1-2 seconds to ensure that the QR code is saved,

- c) The QR code of the charging pile should be identified by the robot's front-facing camera, whereas the QR code of a corridor can be identified by the lateral cameras of the robot.
- d) When incrementally mapping, it is necessary to ensure that the robot's positioning is accurate before identifying and saving the QR code.

5. Clean up barriers

- 1) Before using the spray robot, remove the barriers in the aisle to avoid affecting the working and charging of the robot,

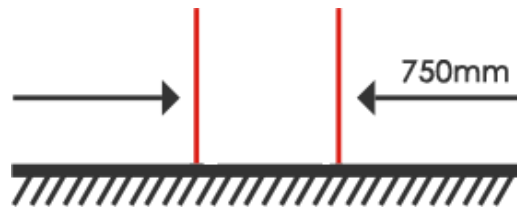

The minimum walking width of the robot is 750mm

- 2) Make sure that there is no vertical step over 10mm within the spraying area, and no objects (books, boards, stones, etc.) over 10mm in height on the working path;



- 3) Make sure that there is no large slope on site



The maximum gradeability of the robot is 8°.

6. Download mobile App

Android 8.0 and above mobile phone Scan the QR code below download the corresponding App and install:



Android mobile browser scan to download the App

7. Turn on, connect the robot

- 1) Turn on the switch to initiate the working mode of the robot;

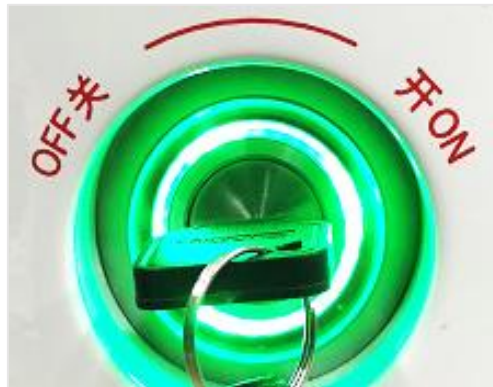

- 2) Turn on the phone wifi, search the wifi network beginning with "BKS-ST-180A", and enter the assigned password "robot123" to connect the robot

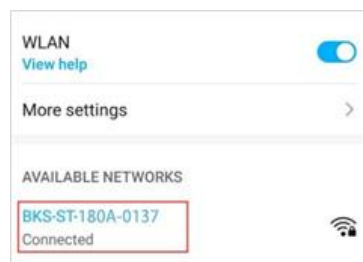

3) Click into the App, you will find the robot beginning with "BKS-ST-180A" (as shown in the following figure), click login;

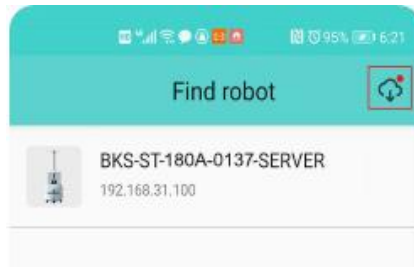

4) Open the App, which shows the interface as below then forward to deploy map,

Screenshots of App interface and function buttons:

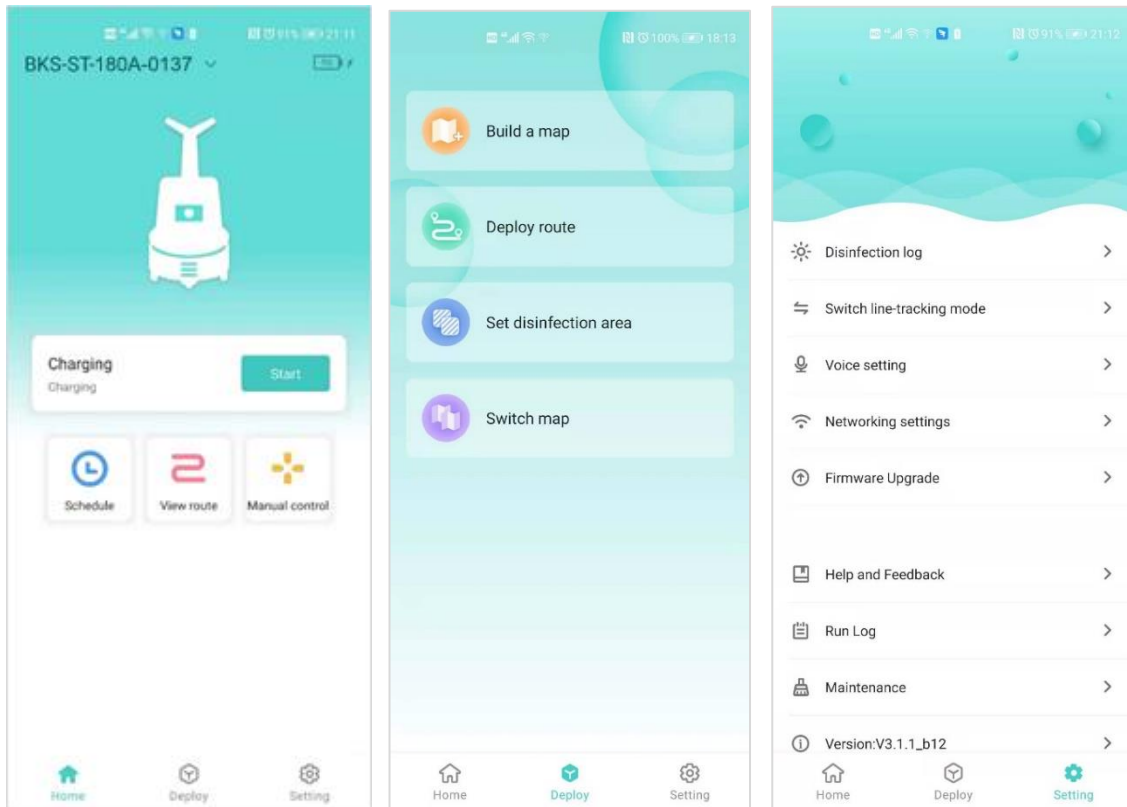

App homepage:

- Robot name and battery
- Robot status
- Scheduled disinfection
- View route
- Manual control

App deployment:

- Build map
- Deploy route
- Set disinfection area
- Switch map

App setting:

- Disinfection log
- Switch loop mode
- Volume
- Networking setting
- Firmware update
- Help and feedback
- Run log
- Maintenance
- App version information

8. Build map

1) Preparation before building the map

- Push the robot **0.5-1m** in front of the charging pile
- Robot power **>50%**

2) Start building the map

Click "Deploy" on the homepage of App to show the "Build Map" button. Click the button to build a two-dimensional spraying map, as shown in the following figure (**Push the robot by hand to build the map**):

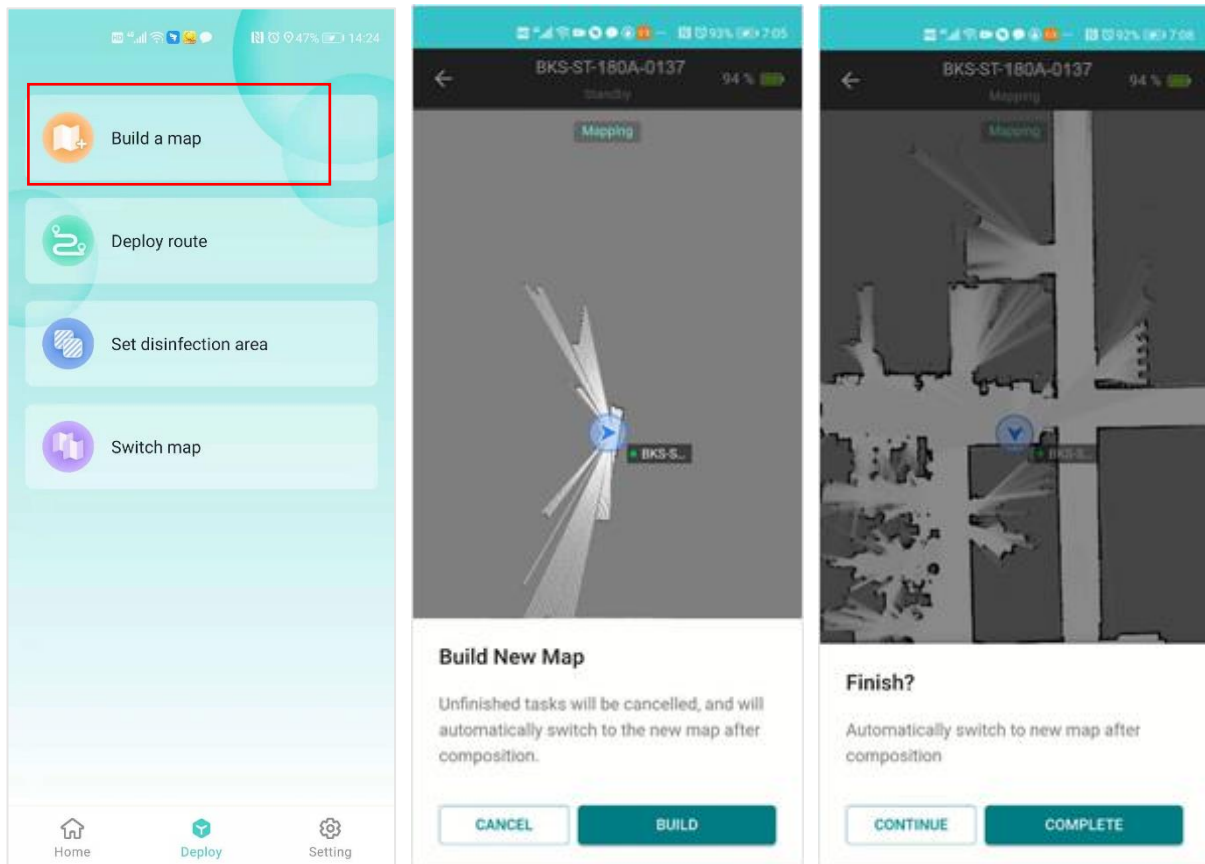

Notifications:

- White radius—the range scanned by the laser;
- Black thick line—the scanned obstacles (special objects such as transparent glass may not be identified)
- Gray area: Area that has not been scanned.

⚠ Attention:

- ① When mapping by hand, push the robot forward slowly in the scene from the **charging pile as the starting point**, and finally return to the charging pile to form a large circle; ;
- ② When mapping, don't be too close to the wall and keep a distance of at least **0.5m**; ;
- ③ The operator must stand behind the robot to avoid leaving noise on the map;
- ④ When turning, **walk slowly** so that the robot can collect as much characteristic point data as possible;
- ⑤ As laser radar does not recognize accurately in abnormal environment (glass, mirror, pure

black object, grid, etc.), it is recommended to carry out appropriate treatment, such as pasting frosted sticker, gray adhesive tape, etc.;

- ⑥ If the working scene is too large/noise, you can use "**Incremental composition**" to enlarge/repair the map;
- ⑦ When passing the QR code, stay in front for more than 1 second, and there will be a **voice prompt** after the entry is successful.

9. Deploy Route/Area setting

9.1 Deploy route setting

The working path of robot consists of the starting point, path points and the disinfection points in series.

Specific setting procedures follow the instructions of App, as shown below:

1) Rapid deployment

- **Charging point:** The position of the robot docking the charging pile。

Click "Deploy route" to enter the route setting mode; push the robot to the charging pile for docking as guided, and click Next to complete the setting.

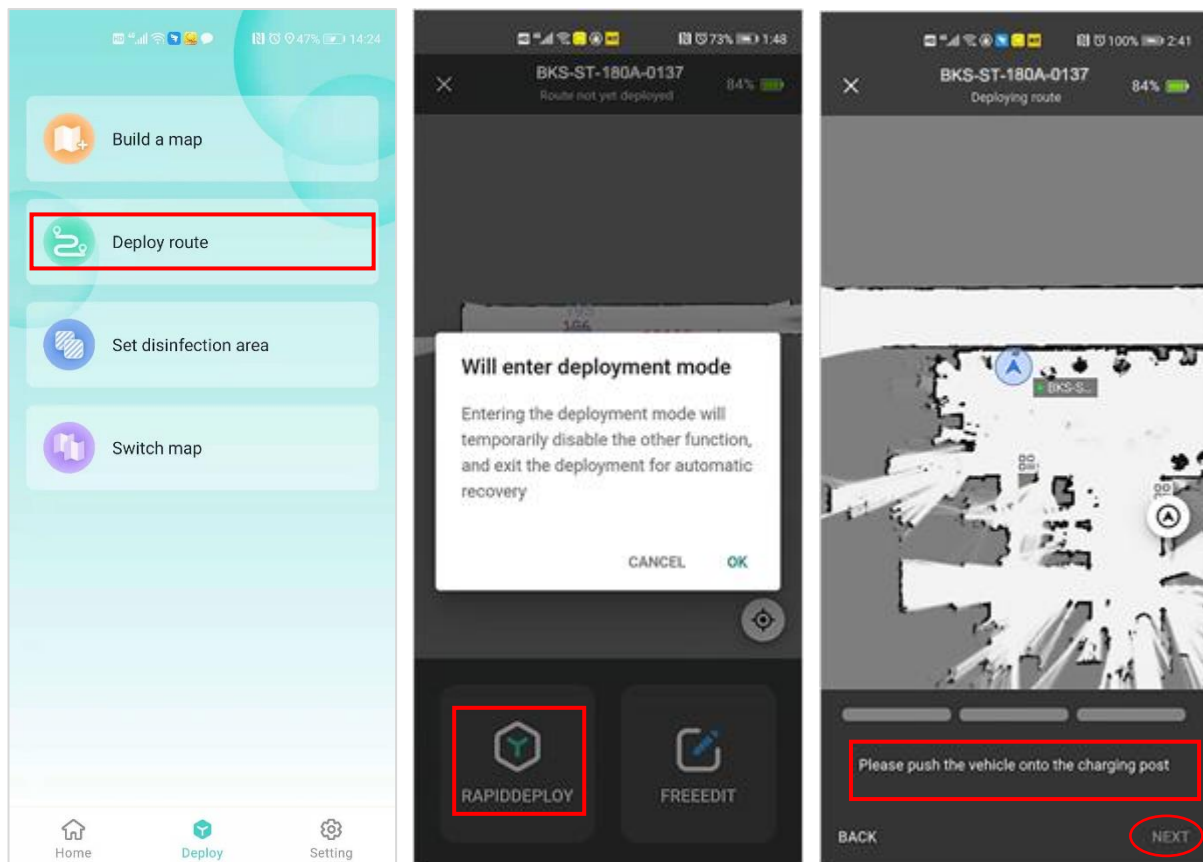

- **Path points and disinfection points:** deploy the points by pushing robot /dragging map
Mark the required location on the map, and then set the corresponding path



point/disinfection point ( The small blue icon is the corresponding location point)

Path points  need to be set for the route that the robot passes through, such as turns and gates, which must be marked (as shown in Figure 2 below: gray points are path points).

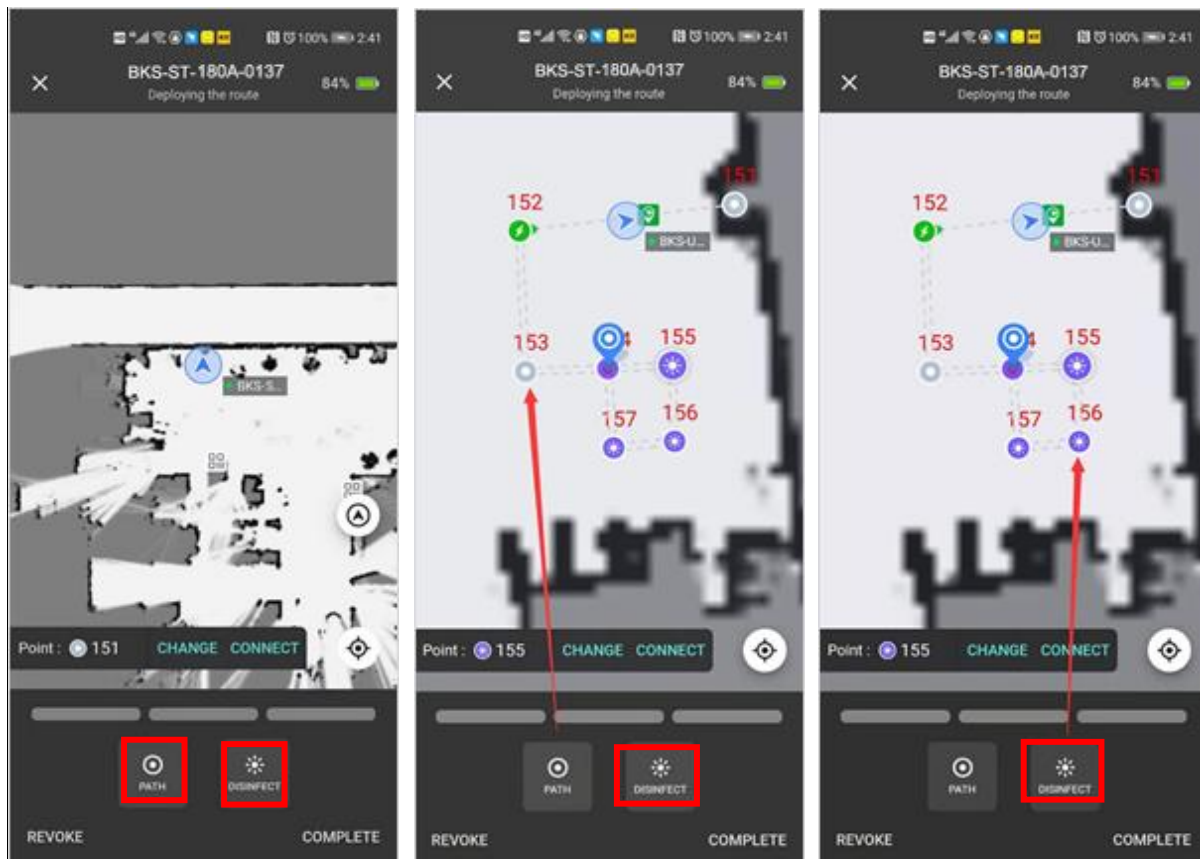
Disinfection points  are set as required for the environmental site (as shown in Figure 3 below: purple icons are disinfection points).



Button "Change" and "Connect" function: Mainly used to connect button "nearby points" in series.

Change  "is to switch point, that is, changing the current point of the robot to the selected nearby point. After this operation, you can click "Connect  " to connect the robot's previous path point or disinfection point with the current point.

"Change" and "Connection", these two functions are mainly designed to facilitate route editing.

2) Free editing-adjust path

- If the route by rapid deployment is not applicable, click "**Free Edit**" to adjust the route. The robot supports adding/deleting/moving points, changing running route, changing disinfection points, etc.

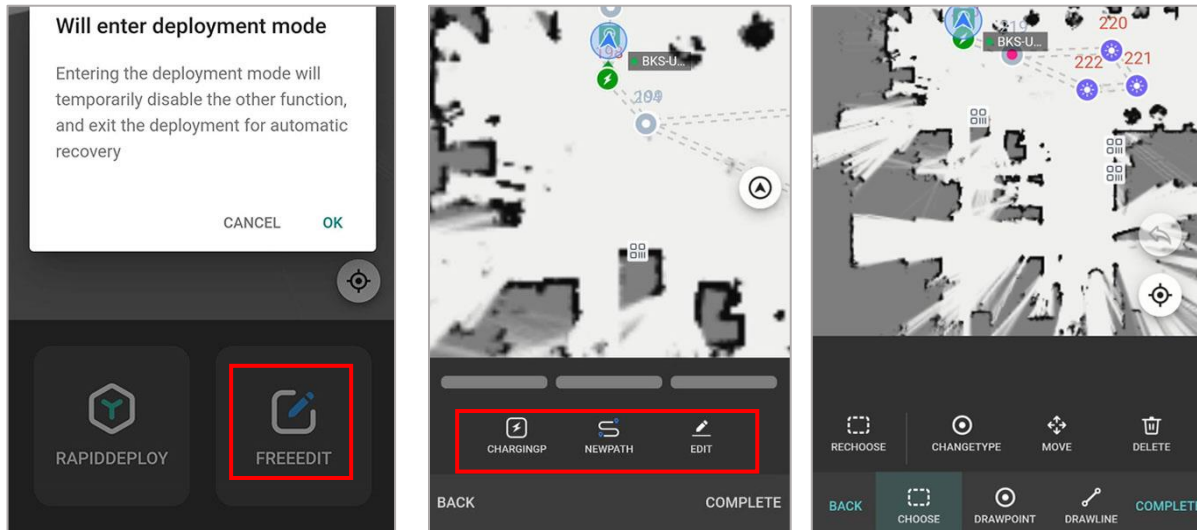

⚠ Attention:

When mapping, the turning should be deployed with waypoints which cannot pass through the wall, as shown in the figure below:

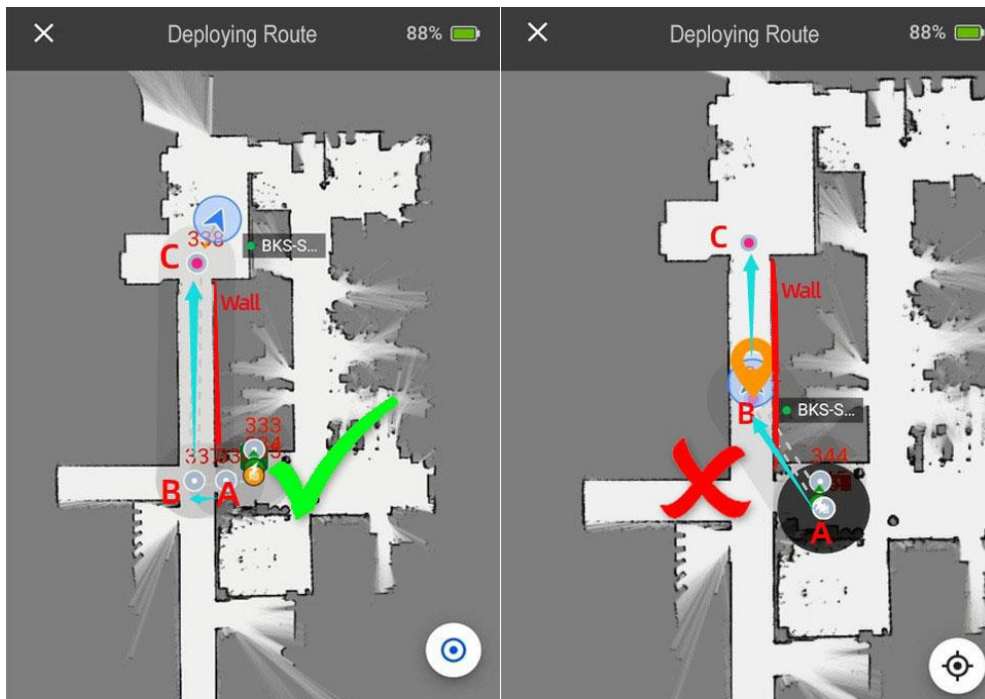

As shown in the figure above, when the robot has to move from A to C, but is obstructed by a wall or an unmovable obstacle in between, the correct path deployment should be A-B-C. B must be set as it is the key node of the turning. The figure on the right shows the wrong deployment, in which the path will go through the wall directly, causing the robot unable to walk.

9.2 Disinfection Area Setting

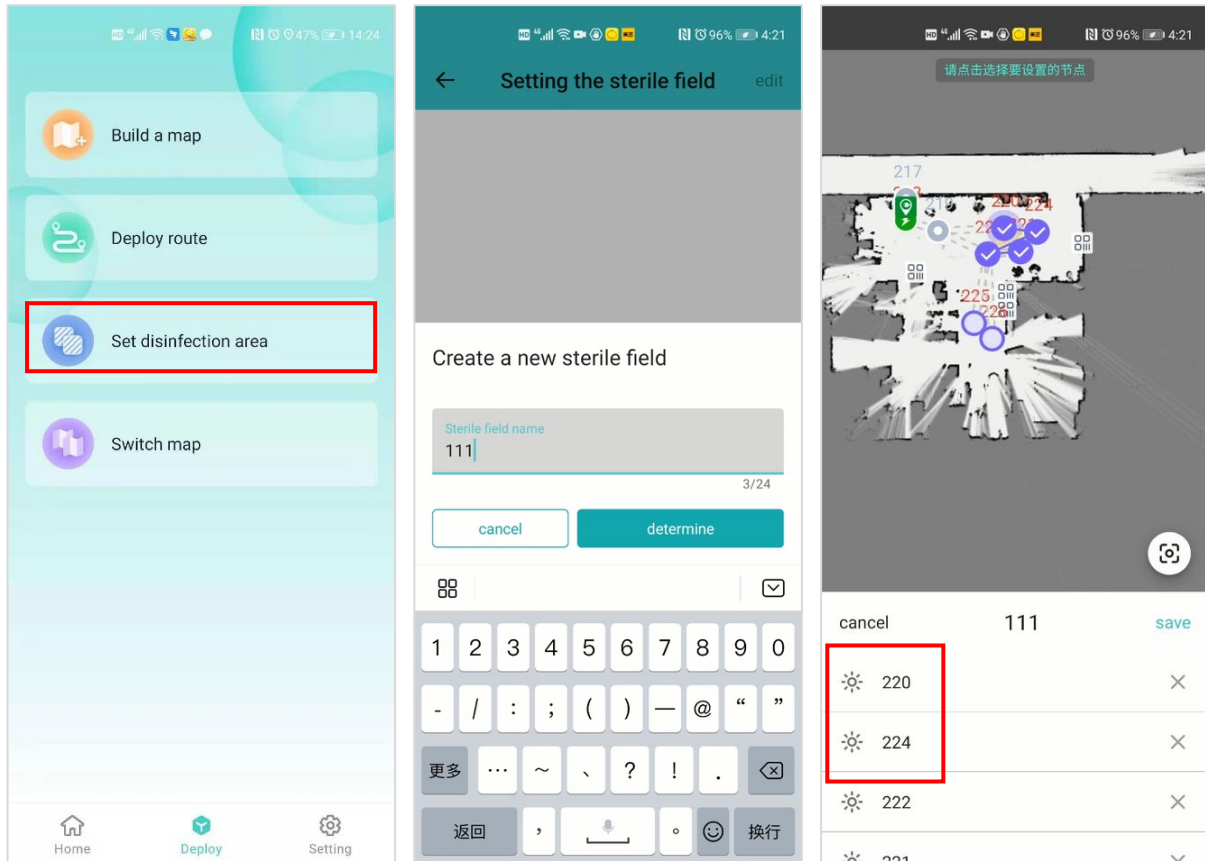

- Click "Set Disinfection Area" menu to "Create New Disinfection Area" and name each disinfection area separately;
- After creating a new disinfection area, click the purple nodes on the map to select the disinfection points in the area, as shown in Figure 4 above: 220 and 224 in the red box are the disinfection points selected in the disinfection area "111"

△Attention: Any area must have 2 or more disinfection points to work normally

10 Schedule setting

You can freely set (add/modify) the disinfection schedule as required (see the figures below).

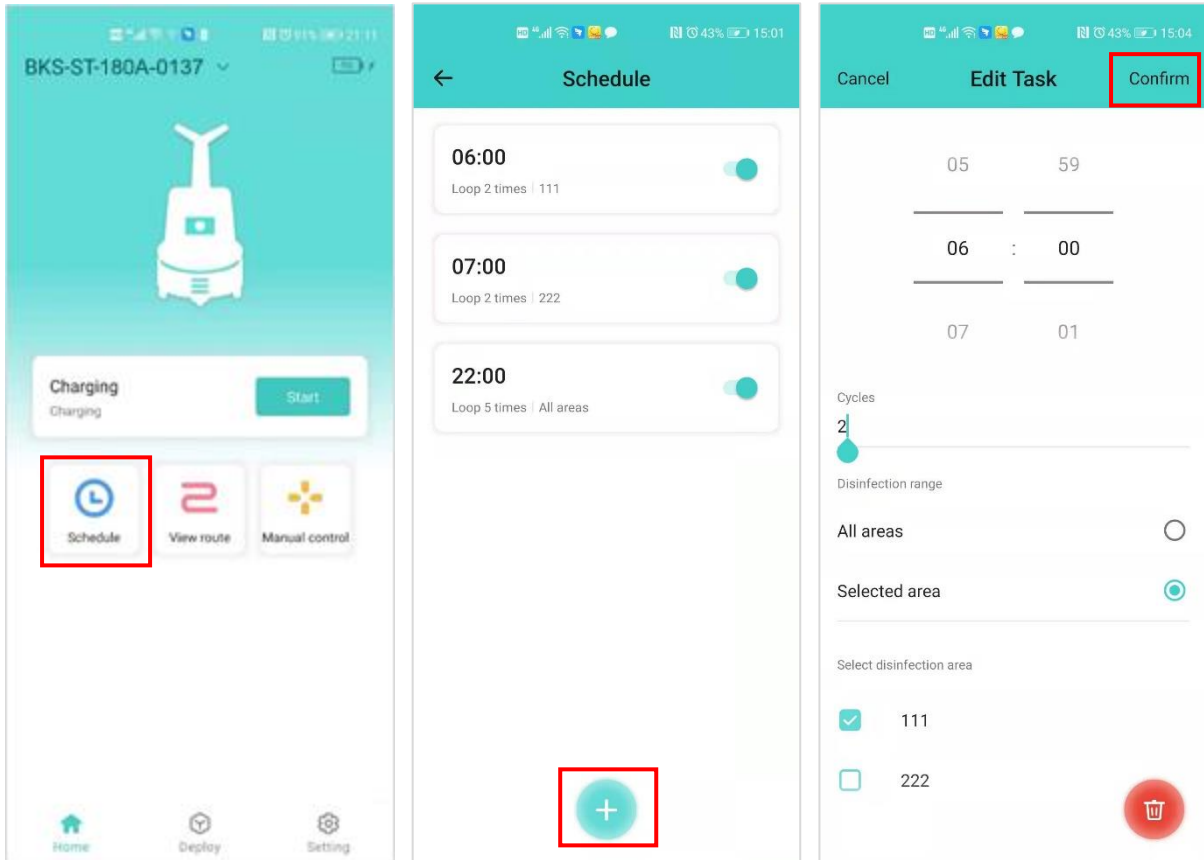

Click "Schedule" on the homepage to enter the editing interface.

Then click "+" button to set the starting time and disinfection area.

After the time and area are set, click "Confirm" in the upper right corner to save the setting

11. Other settings

There are also functions such as voice prompts, volume adjustment, maintenance prompts and other functions such as disinfection log, line patrol mode selection, firmware upgrade, etc:

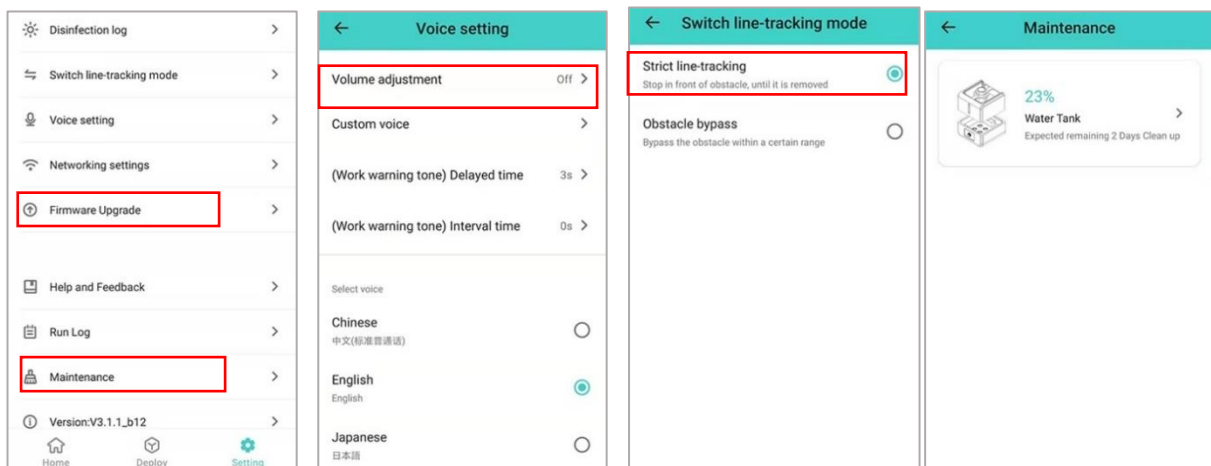

12. Start to work

12.1 Add liquid

The working principle of the disinfecting robot is to release the disinfecting agent into the disinfecting area automatically by rapidly atomizing the disinfecting agent as dry fog style, to complete the terminal disinfection with high efficiency and supersaturation. Please use in strict accordance with the specifications and requirements of the disinfectant

*Reference of using Disinfectant

Please reference to the content “06/About “Terminal Disinfection” on page 2 of this manual.

o

△Attention: The maximum volume of the tank is 18L, it is recommended that the maximum volume of liquid should not exceed 15L, in order to avoid overflow in up and down ramps, access trenches, thresholds, emergency stops and other working conditions.

12.2 Start spraying

When all preparations are ready, return to the homepage of App, click the "start" button, and the robot will start spraying according to the settings.

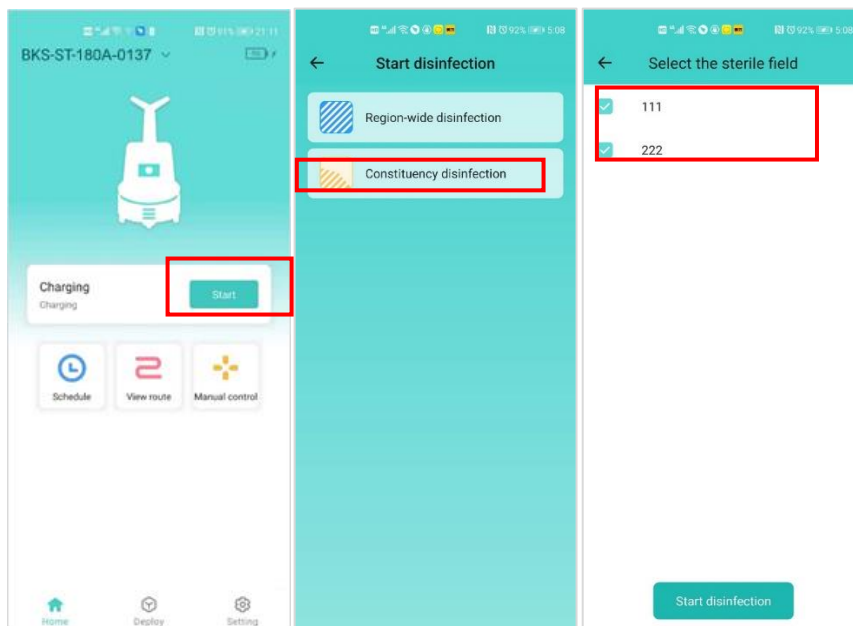

Attachment: Upgrade

⚠ Attention: The firmware upgrade process takes about 5 minutes, during which no operation

Step1: Download the firmware

Connect the mobile phone to the external network (LAN/4G), open the App-find the robot, if there is a small red dot in the upper right corner, it means there is a new version of the firmware that can be upgraded:

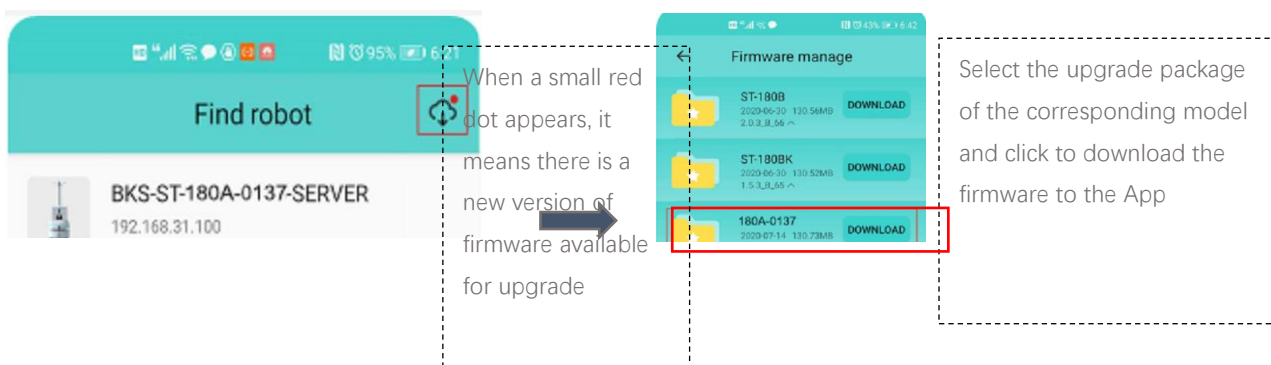

Step 2: Connect to the robot and upload the firmware to the robot body for upgrade

Turn on the mobile phone wifi, find the robot, enter the password“robot123” to connect:

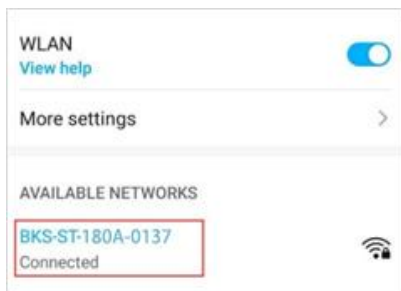

Step 3: Upgrade firmware from App to robot

Click into App, Setting-Firmware upgrade, click it and wait for about 5 minutes to complete

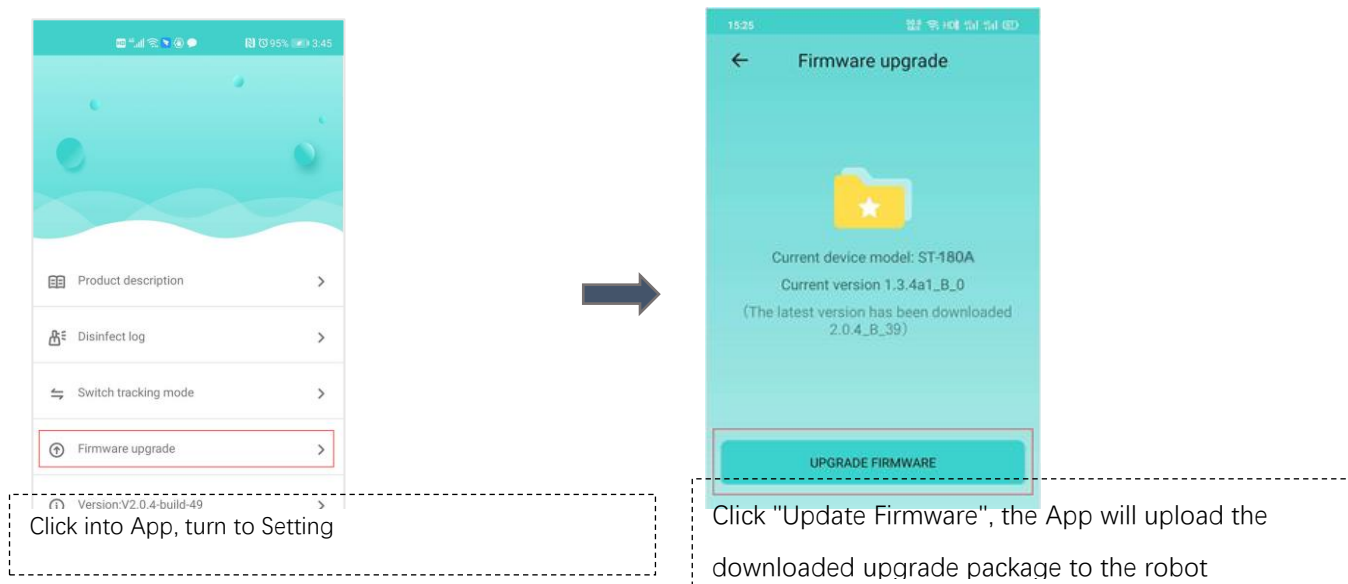



www.boocax.com

Business cooperation / after-sales: 0086-400-161-8661

| Beijing Headquarter: | Shenzhen Branch: | Shandong Factory | Henan Factory |
|---|--|---|---|
| Room 606, Jianjin Center, Yongtaiyuan A No.1, Qinghe, Haidian District, Beijing | 3F, Building 10, COFCO Fu'an Robotics Industrial Park, Fuyong Street, Baoan District, Shenzhen | No.269 Hengfeng Road, Zoucheng Central Electromechanical Industrial Park, Ji'ning, Shandong | #01 Robot Industrial Park, the intersection of Fenshan Road and Beihuan Road, Economic Development Zone, Sanmenxia City, Henan. |